



# *NovoSoft 165 Series Water Softener Operation Manual*

---

**Note:**

1. Read all instructions carefully before operation.
2. Avoid pinched o-rings during installation by applying (provided with install kit) NSF certified lubricant to all seals.

Rev 6, January 12, 2010

---

# **TABLE OF CONTENTS**

Water Softener Gallon Setting Chart.....	2
System Specifications.....	3
Introduction.....	4
Programming.....	5
General Valve Installation.....	7
Start-up Instructions.....	7
System Configuration.....	8
Maintenance.....	10
Control Valve Exploded View.....	11
Control Valve Parts List.....	12
Trouble Shooting.....	13
Guarantee.....	14

# Water Softener Gallon Setting Chart

Water Softener Gallon Setting Chart															
Instructions: First select the chart for your model of water softener, then simply line up the number of people living in the home with the hardness of the water and select the appropriate gallon setting for your model.															
at 6lbs salt/CF															
<b>.75 CF</b>															
Total Hardness in Grains per US Gallon															
		10	15	20	25	30	35	40	45	50					
	1	1575	1025	750	585	475	396	338	292	255					
	2	1500	950	675	510	400	321	263	217						
Number of people living in the home	3	1425	875	600	435	325									
	4	1350	800	525											
	5	1275	725												
	6	1200													
	7	1125													
	8	1050													
	Softener could be undersized if # of people and hardness line up in this shaded area. Consideration may be given to a larger size unit to meet your needs.														
	<b>1.0 CF</b>														
Total Hardness in Grains per US Gallon															
		10	15	20	25	30	35	40	45	50	55	60	65		
	1	2125	1392	1025	805	658	554	475	414	365	325	292	263		
	2	2050	1317	950	730	583	479	400	339	290	250	217			
Number of people living in the home	3	1975	1242	875	655	508	404	325							
	4	1900	1167	800	580	433									
	5	1825	1092	725											
	6	1750	1017												
	7	1675	942												
	8	1600	867												
	9	1525													
	10	1450													
Softener could be undersized if # of people and hardness line up in this shaded area. Consideration may be given to a larger size unit to meet your needs.															
<b>1.5 CF</b>															
Total Hardness in Grains per US Gallon															
		10	15	20	25	30	35	40	45	50	55	60	65	70	75
	1	3225	2125	1575	1245	1025	868	750	658	585	525	475	433	396	365
	2	3150	2050	1500	1170	950	793	675	583	510	450	400	358	321	290
Number of people living in the home	3	3075	1975	1425	1095	875	718	600	508	435	375	325			
	4	3000	1900	1350	1020	800	643	525	433						
	5	2925	1825	1275	945	725	568								
	6	2850	1750	1200	870	650									
	7	2775	1675	1125	795										
	8	2700	1600	1050											
	9	2625	1525	975											
	10	2550	1450												
Softener could be undersized if # of people and hardness line up in this shaded area. Consideration may be given to a larger size unit to meet your needs.															
<b>2.0 CF</b>															
Total Hardness in Grains per US Gallon															
		10	15	20	25	30	35	40	45	50	55	60	65	70	75
	1	4325	2858	2125	1685	1392	1182	1025	903	805	725	658	602	554	512
	2	4250	2783	2050	1610	1317	1107	950	828	730	650	583	527	479	437
Number of people living in the home	3	4175	2708	1975	1535	1242	1032	875	753	655	575	508	452	404	362
	4	4100	2633	1900	1460	1167	957	800	678	580	500	433			
	5	4025	2558	1825	1385	1092	882	725	603						
	6	3950	2483	1750	1310	1017	807								
	7	3875	2408	1675	1235	942									
	8	3800	2333	1600	1160	867									
	9	3725	2258	1525	1085										
	10	3650	2183	1450											
Softener could be undersized if # of people and hardness line up in this shaded area. Consideration may be given to a larger size unit to meet your needs.															
<b>3.0 CF</b>															
Total Hardness in Grains per US Gallon															
		10	15	20	25	30	35	40	45	50	55	60	65	70	75
	1	6525	4325	3225	2565	2125	1811	1575	1392	1245	1125	1025	940	868	805
	2	6450	4250	3150	2490	2050	1736	1500	1317	1170	1050	950	865	793	730
Number of people living in the home	3	6375	4175	3075	2415	1975	1661	1425	1242	1095	975	875	790	718	655
	4	6300	4100	3000	2340	1900	1586	1350	1167	1020	900	800			
	5	6225	4025	2925	2265	1825	1511	1275	1092						
	6	6150	3950	2850	2190	1750	1436	1200							
	7	6075	3875	2775	2115	1675	1361	1125							
	8	6000	3800	2700	2040	1600									
	9	5925	3725	2625	1965										
	10	5850	3650	2550											
Softener could be undersized if # of people and hardness line up in this shaded area. Consideration may be given to a larger size unit to meet your needs.															

Figure 1. Gallon Setting Chart

# System Specifications

Model	Capacity Grains			Flow Rate		Mineral Tank Size	Resin Cu. Ft.	Brine Tank / Cabinet Size Inches	Salt Cap Lbs	Shipping Weight Lbs
	@ 10 lbs/cu ft	@ 6 lbs/cu ft (Factory Setting)	@ 3 lbs/cu ft	Service USGPM	Backwash USGPM					
NVO165-75	19,875	<b>16,500</b>	10,500	8.0	1.5	8 x 44	0.75	15.8 x 32.1	250	84
NVO165-100	26,500	<b>22,000</b>	14,000	10.0	2.0	9 x 48	1.00	18.1 x 34.5	300	104
NVO165-150	39,750	<b>33,000</b>	21,000	12.0	2.4	10 x 54	1.50	18.1 x 34.5	300	133
NVO165-200	53,000	<b>44,000</b>	28,000	13.0	3.0	12 x 52	2.00	20.3 x 37.4	400	153
NVO165-300	79,500	<b>66,000</b>	42,000	15.0	5.0	14x65	3.00	20.3 x 37.4	400	220
NVO165-75C	19,875	<b>16,500</b>	10,500	8.0	2.0	9 x 35	0.75	13.0x22.5x44.0	300	84
NVO165-100C	26,500	<b>22,000</b>	14,000	10.0	2.4	10 x 35	1.00	13.0x22.5x44.0	300	104

Figure 2. Specifications

- Maximum Water Temperature = 110°F (43°C)
- Maximum Operating Pressure = 100 PSIG (689 kPa)
- Voltage = 110 volts standard
- Pipe Size = 3/4"
- At the stated service flow rates, the pressure drop through these devices will not exceed 15 psig.
- Changing salt settings from factory setting may require changing injector sizes to achieve stated capacities.
- The manufacturer reserves the right to make product improvements which may deviate from the specifications and descriptions stated herein, without obligation to change previously manufactured products or to note the change.

## How Your Water Conditioner Works

The principle behind water softening is simple chemistry. A water softener contains resin beads which hold electrically charged ions. When hard water passes through the softener, calcium and magnesium ions are attracted to the charged resin beads. It's the resulting removal of calcium and magnesium ions that produces soft water.

This system is controlled with simple, user-friendly electronics displayed on a LCD screen. The main page displays the current time and the remaining gallons in meter mode or the remaining days in calendar clock mode.

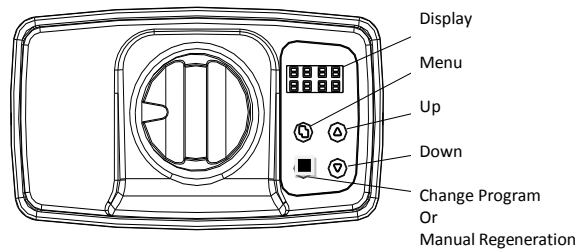

Figure 3. Valve Display

## System Initialization

When power is supplied to the control, the screen will display TIME OF DAY AND DEFAULT GALLON SETTING. If the valve is not in service it will read "CANATURE" while the valve returns to the service position.

# Programming

1. Press 'MENU' to enter programming. If the system has been inactive, you may have to hold and press 'MENU' until you hear a beep to unlock the display screen. Press '▲' or '▼' to select which setting to modify.
2. To change setting, press 'ENTER'. When the display flashes, the value may be changed. Press '▲' or '▼' to change the value. Press 'ENTER' to accept the value.
3. Press 'MENU' to return to previous menu.

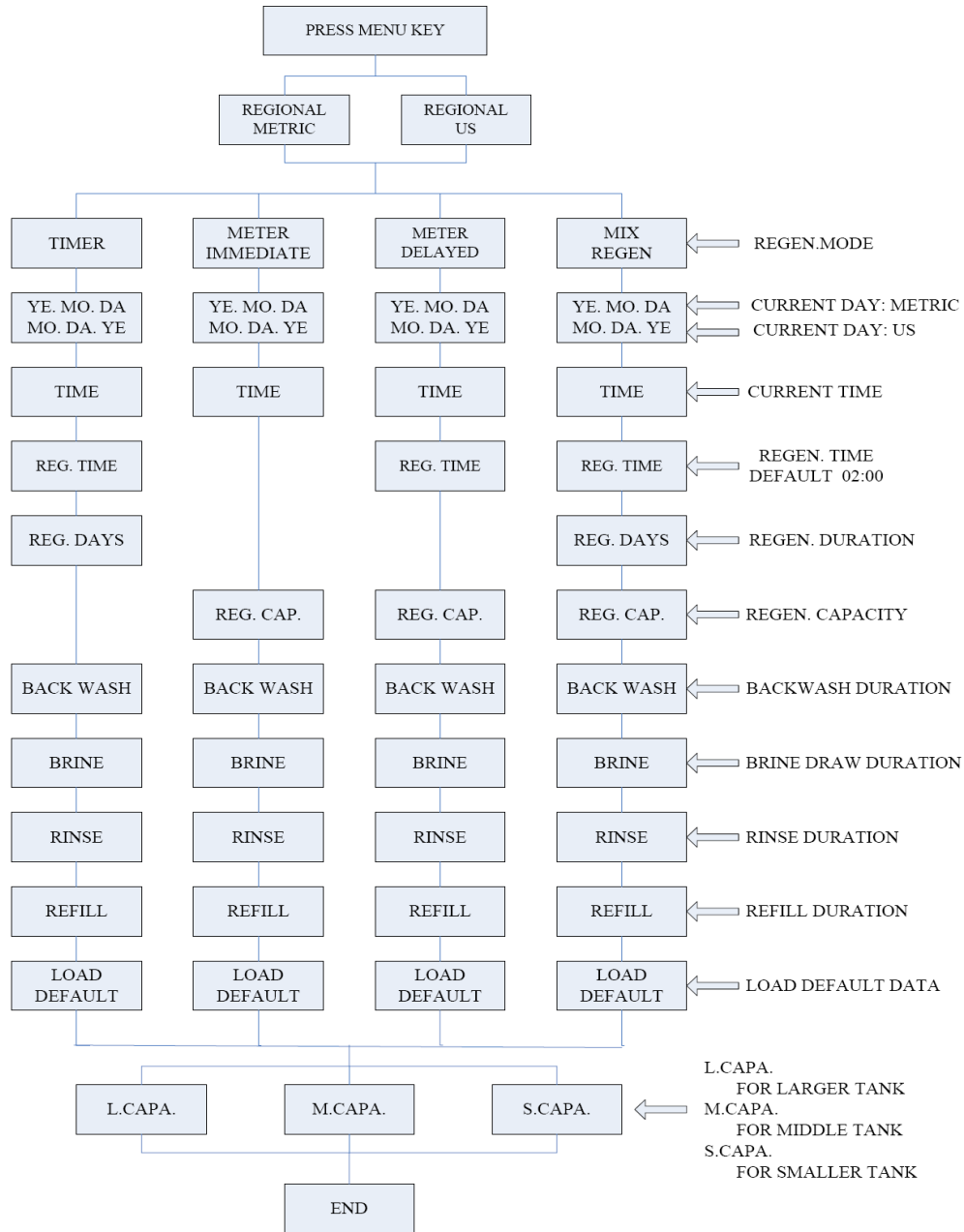

Figure4. Program Flow Chart

## Program Options

Depending on the current option settings, some parameters cannot be viewed or set.

Program Mode			
PARAMETER		OPTIONS	DESCRIPTION
1	REGIONAL	METRIC	This option controls whether cubic meters or US gallons is used for the volume display and the format of the day, year, and month.
		US	
2	REGENERATION MODE	METER DELAYED	This is the most common setting. When the volume remaining reaches zero gallons, the system will initiate a regeneration at the next pre-set regeneration time.
		METER IMMEDIATE	The unit will initiate a regeneration immediately after the volume remaining reaches zero.
		TIMER	The unit will initiate a regeneration at the next pre-set regeneration time based on the interval of days between regeneration days.
		MIX REGEN	<b>Meter initiated with Day Override.</b> When the volume remaining reaches zero gallons, the system will initiate a regeneration at the next pre-set regeneration time. If the days between regeneration is reached before the remaining volume reaches zero, the system will override the meter setting and initiate a regeneration.
4	DATE		Set date of installation. This value is fixed and does not change.
5	TIME		Set current time.
6	REG TIME		This setting controls the time of day when a regeneration cycle will start.
7	REG. DAYS		The user can manually enter values for regeneration day intervals.
8	REG. CAP.		The user can manually enter values system capacity.
9	BACKWASH		This option controls the length of time in minutes for the unit to clean the bed by reversing the flow of water upwards through the bed and out to the drain.
10	BRINE		This option controls the length if time in minutes for the unit to draw regenerant (brine for softeners) from the second tank and slowly rinse it from the top to bottom of the tank.
11	RINSE		This option controls the length of time to give the tank a final rinse from the top to the bottom in order remove any last traces of the regenerant (brine) from the tank.
12	REFILL		This option controls the length of time the brine valve will open to refill the second tank (brine tank for softeners) with water in order to produce the regenerate solution (brine for softeners) for the next regeneration cycle. The water is accurately measured through the valves brine line flow control to make a precise quantity of regenerant solution.
13	LOAD DEFAULT	L.CAPA.	<b>It is not recommended to use any of these options.</b> The function of this option is to load pre-set values of BACKWASH, BRINE, RINSE, and REFILL for large, medium, and small capacity systems. <b>We recommend to use the settings as specified in the SYSTEM CONFIGURATION section of this manual.</b>
		M.CAPA	
		S.CAPA	

Figure 5. Program Options

## Manual Regeneration

1. If the system has been inactive, you may have to hold and press '□' until you hear a beep to unlock the display screen. Press "■" and hold to initiate a manual regeneration. When the valve reaches any cycle position, pressing any key will automatically advance the valve to the next position.

## General Valve Installation

Water Pressure	Minimum 25 PSI
Electrical Supply	Uninterrupted 115V AC
Existing Plumbing	Free of any deposits or build-ups inside pipes.
Softener Location	Locate close to drain and connect according to plumbing codes
Bypass Valves	Always provide for bypass valve if unit is not equipped with one.
Plumbing	Softener and or other water treatment equipment should be installed to local plumbing codes

	<p><b>CAUTION</b></p> <ul style="list-style-type: none"> <li>▪ Do not exceed 120 psi water pressure.</li> <li>▪ Do not exceed 110°F water temperature.</li> <li>▪ Do not subject unit to freezing conditions.</li> </ul>
---	--

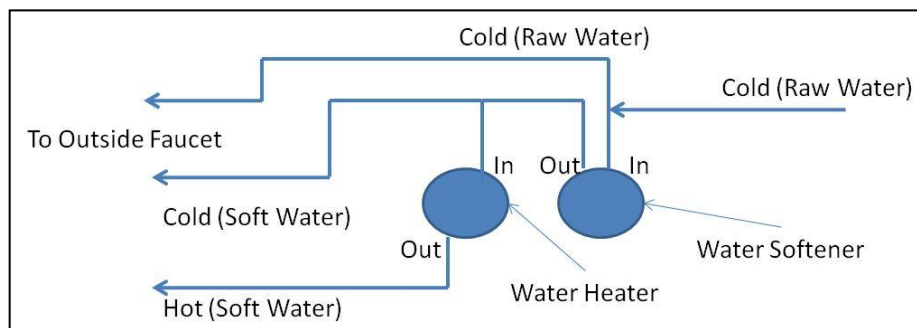

Figure 6. Piping Diagram

1. Locate the softener tank and brine tank close to a drain where the system will be installed. The surface should be clean and level.
2. Perform all plumbing according to local plumbing codes.
  - Use a ½" minimum pipe or tubing size for the drain line
  - Use a ¾" pipe or tubing for backwash flow rates that exceed 7 gpm or length that exceeds 20ft (6 m)
3. Any solder joints near the valve must be done before connecting any piping to the valve. Always leave at least 6" (152 mm) between the valve and joints when soldering pipes that are connected to the valve. Failure to do this could cause damage to the valve.
4. If the valve is not installed on the tank, cut the 1" central pipe flush with top of each tank. Lubricate the large o-ring on the valve that seals against the tank. Screw the valve on to the tank. Be careful to not cross thread the valve into the tank. Only use silicone lubricant.
5. Connect the drain line to the valve.
6. Connect the brine line from the brine tank to the valve.
7. Add water until there is approximately 1" (25 mm) of water above the grid plate. If the tank does not have a grid, add water until it is above the air check in the brine tank. Do not add salt to the brine tank at this time.
8. Place the unit in the bypass position.
9. Slowly turn on the main water supply.
10. At the nearest cold treated water tap nearby remove the faucet screen, open the faucet and let water run a few minutes or until the system is free of any air or foreign material resulting from the plumbing work. Close the water tap when water runs clean, then proceed to start up instructions.

## Start up Procedure

1. Plug the valve into an approved power source.
2. When power is supplied to the control, the screen will display TIME OF DAY and DEFAULT GALLON SETTING. If the valve is not in service it will read "CANATURE" while the valve returns to the service position.
3. If the system has been inactive, you may have to hold and press '□' until you hear a beep to unlock the display screen. Press "■" to initiate a manual regeneration and advance the valve to the Backwash position. Open the inlet on the bypass valve slowly and allow water to enter the unit. Allow all air to escape from the unit before turning the water on fully then allow water to run to drain for 3-4 minutes or until all media fines are washed out of the softener or filter.
4. Press the "■" to advance to the BRINE position. Check the water level in the brine tank to insure the valve is drawing brine properly.
5. Press the "■" to advance to the RINSE position. Check the drain line flow. Allow the water to run for 3-4 minutes or until the water is clear.
6. Press the "■" to advance to the REFILL position. Check that the valve is filling water into the brine tank. Allow the valve to refill for the correct amount of time as displayed on the screen to insure a proper brine solution for the next regeneration.
7. Press the "■" to advance to the SERVICE position. Open the outlet valve to the bypass, then open the nearest treated water faucet and allow the water to run until clear, close the tap and replace the faucet screen.
8. Put salt into the brine tank.

## Control Operation During A Power Failure

In the event of power failure, the valve will keep track of the time and day for 48 hours. The programmed settings are stored in a non-volatile memory and will not be lost during a power failure. If power fails while the unit is in regeneration, the valve will return to the service position once power is restored. If the valve misses a scheduled regeneration due to a power failure, it will queue a regeneration at the next regeneration time once power is restored.

## System Configuration

RESIN VOLUME	SYSTEM CAPACITY (GRAINS)				CYCLE TIME (MINUTES)			REFILL TIME (MINUTES) @ 0.30 GPM BLFC			
	@ 15 lbs/cu ft	@ 10 lbs/cu ft	@ 6 lbs/cu ft (Factory Setting)	@ 3 lbs/cu ft	BACKWASH	BRINE/RINSE	RINSE	@ 15 lbs/cu ft	@ 10 lbs/cu ft	@ 6 lbs/cu ft (Factory Setting)	@ 3 lbs/cu ft
0.75	22,500	19,875	16,500	10,500	10.0	60.0	10.0	13	8	5	3
1.00	30,000	26,500	22,000	14,000	10.0	60.0	10.0	17	11	7	3
1.50	45,000	39,750	33,000	21,000	10.0	60.0	10.0	25	17	10	5
2.00	60,000	53,000	44,000	28,000	10.0	60.0	10.0	33	22	13	7
3.00	90,000	79,500	66,000	42,000	10.0	60.0	10.0	50	33	20	10

Figure 7. Valve Cycle Settings

## Injector and Drain Line Flow Control

Suggested Softener Valve Configuration			
Tank Size (Diameter)	Injector Set	Brine Line Flow Control (BLFC)	Drain Line Flow Control (DLFC)
6"	#000 Brown	(0.30 GPM)	#1 (1.5 GPM)
7"			#2 (2.0 GPM)
8"	#1 White		#3 (2.4 GPM)
9"			#4 (3.5 GPM)
10"			#6 (4.0 GPM)
12"	#2 Blue		#7 (5.0 GPM)
13"			none
14"	#3 Yellow		
16"			

Figure 8. Valve Configurations

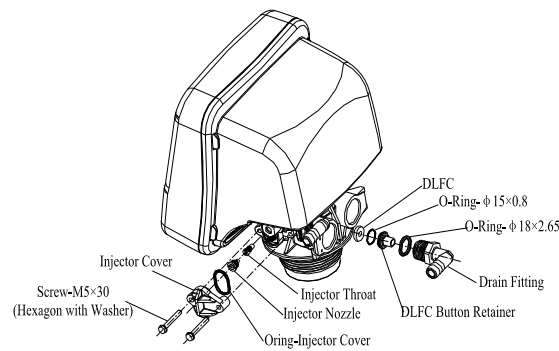

Figure 9. Valve Configuration

## **Installing the Bypass valve**

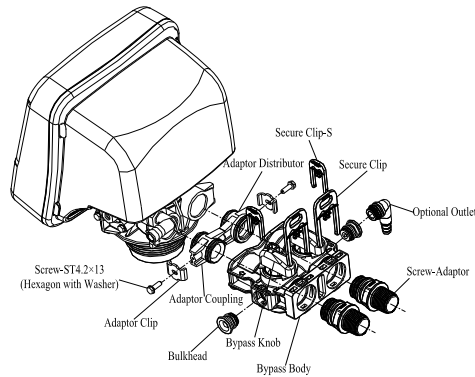

Figure 10. Valve Configurations

## **Automatic Bypass**

The regeneration cycle lasts approximately 75 minutes, after which soft water service will be restored. During regeneration, hard water is automatically bypassed for use in the household. Hot water should be used as little as possible during this time to prevent hard water from filling the water heater. This is why automatic regeneration is set for sometime during the night and manual regenerations should be performed when little or no water will be used in the household.

## **Safety Float**

The brine tank is equipped with a safety float which prevents your brine tank from overflowing as a result of a malfunction such as a power failure.

## **New Sounds**

You may notice new sounds as your water softener operates. The regeneration cycle lasts approximately 2-1/2 hours. During this time, you may hear water running intermittently to the drain.

## **Manual Bypass**

In the case of emergency, such as an overflowing brine tank, you can isolate your water softener from the water supply using the bypass valve located at the back of the control. In normal operation the bypass is open with the on/off knobs in line with the inlet and outlet pipes. To isolate the softener, simply rotate the knobs counter clockwise until they lock. You can use your water related fixtures and appliances as the water supply is bypassing the softener. However, the water you use will be hard. To resume soft water service, open bypass valve by rotating the knobs clockwise.

# Maintenance

## Adding Salt

Use only crystal water softener salt. Check the salt level monthly. It is important to maintain the salt level above the water level. To add salt, simply lift the salt lid and add the salt directly into the brine tank. Be sure the brine well cover is on and fill only to the height of the brine well.

## Bridging

Humidity or wrong type of salt may create a cavity between the water and the salt. This action, known as “bridging”, prevents the brine solution from being made, leading to your water supply being hard. If you suspect salt bridging, carefully pound on the outside of the brine tank or pour some warm water over the salt to break up the bridge. This should always be followed up by allowing the unit to use up any remaining salt and then thoroughly cleaning out the brine tank. Allow four hours to produce a brine solution, and then manually regenerate the softener.

## Care of Your Softener

To retain the attractive appearance of your new water softener, clean occasionally with mild soap solution. Do not use abrasive cleaners, ammonia or solvents. Never subject your softener to freezing or to temperatures above 120°F.

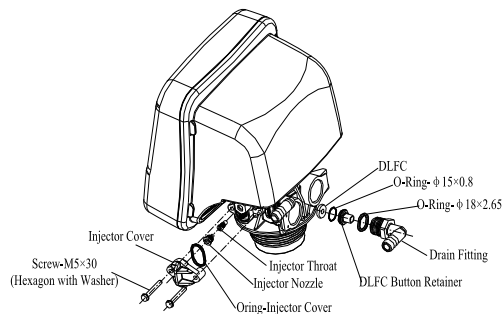

Figure 11. Injector Assembly

## Cleaning the Injector Assembly

Sediment, salt and silt will restrict or clog the injector. A clean water supply and pure salt will prevent this from happening.

The injector assembly is located on the right side of the control valve. This assembly is easy to clean.

Shut off the water supply to your softener and reduce the pressure by opening a cold soft water faucet. Using a screwdriver, remove the two screws holding the injector cover to the control valve body. Carefully remove the assembly and disassemble as shown in Figure 6. The injector orifice is removed from the valve body by carefully turning it out with a large screwdriver. Remove the injector throat the same way. Carefully flush all parts including the screen. Use a mild acid such as vinegar or Pro-Rust Out to clean the small holes in the orifice and throat.

Re-assemble using the reverse procedure.

## Resin Cleaner

An approved resin cleaner **must** be used on a regular basis if your water supply contains iron. The amount of resin cleaner and frequency of use is determined by the quantity of iron in your water (consult your local representative or follow the directions on the resin package).

# Control Valve Exploded View

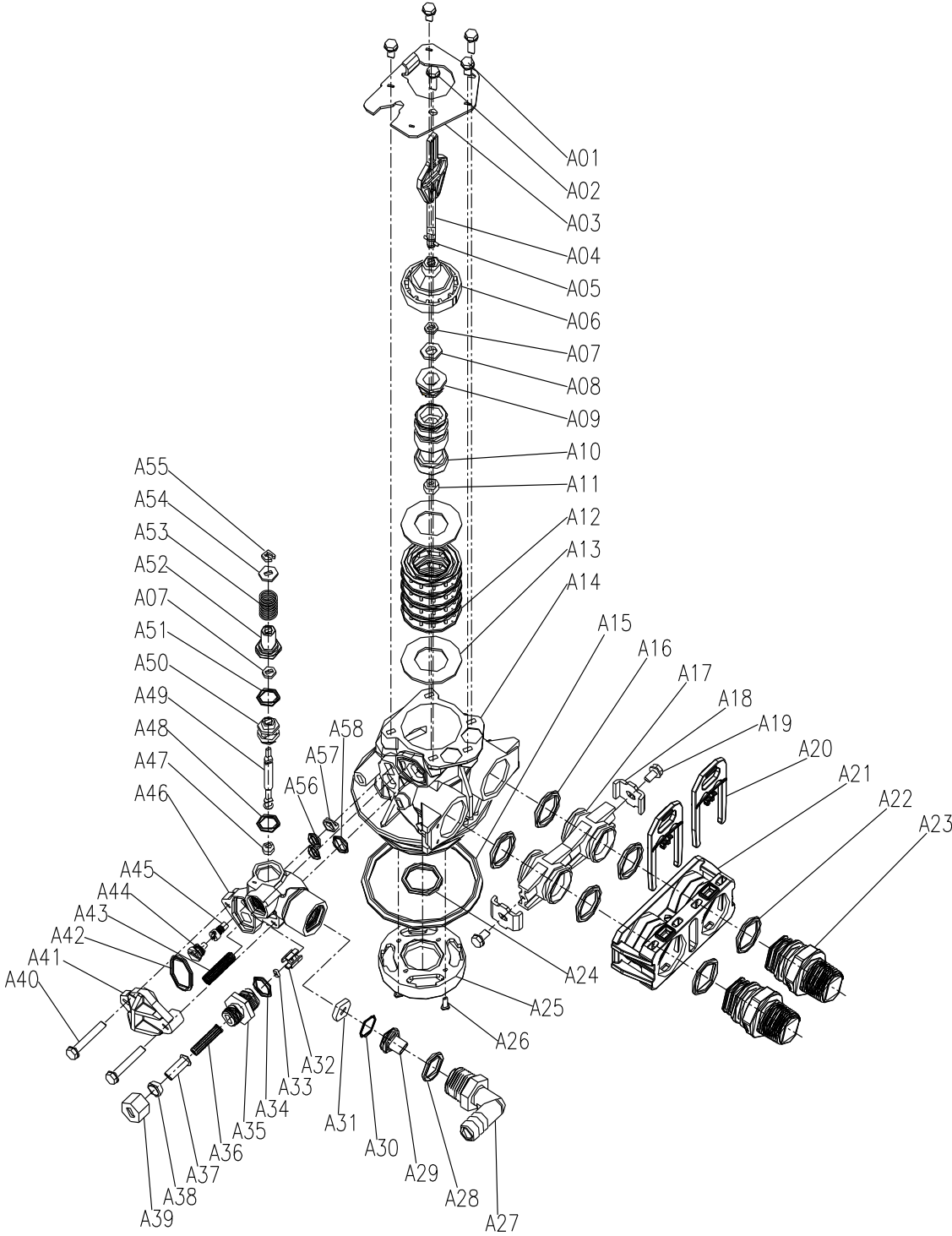

See parts listing on next page (12)

## Control Valve Parts List

Item No.	Part No.	Part Discription	Quantity
A01	05056087	Screw-M5×12(Hexagon)	3
A02	05056088	Screw-M5×16(Hexagon with Washer)	2
A03	05056047	End Plug Retainer	1
A04	05010081	Bnt65 Piston Rod	1
A05	05056097	Piston Pin	1
A06	05056023	End Plug	1
A07	05056070	Quad Ring	2
A08	05056024	End Plug Washer	1
A09	05056022	Piston Retainer	1
A10	05056181	Piston (Electrical)	1
A11	05056104	Muffler	1
A12	05056021	Spacer	4
A13	05056073	Seal	5
A14	05056019	Bnt65 Valve Body	1
A15	05056063	O-ring- φ 78.74×5.33	1
A16	05056129	O-ring- φ 23×3	4
A17	05056025	Adaptor Coupling	2
A18	05056044	Adaptor Clip	2
A19	05056090	Screw-ST4.2×13(Hexagon with Washer)	2
A20	21709003	Secure Clip	2
A21	05056140	Valve Connector	1
A22	05056065	O-ring- φ 23.6×2.65	2
A23	21319006	Screw Adaptor	2
A24	26010103	O-ring- φ 25×3.55	1
A25	07060007	Valve Bottom Connector	1
A26	13000426	Screw-ST2.9×13(Large Wafer)	2
A27	05056038	Drain Fitting	1
A28	26010003	O-Ring- φ 18×2.65	1
A29	05056036	DLFC Button Retainer	1
A30	05056079	O-Ring- φ 15×0.8	1
A31	05056143	DLFC-2#	1
A32	05056035	BLFC Button Retainer	1
A33	05056191	BLFC-2#	1
A34	05056138	O-Ring- φ 14×1.8	1
A35	05056100B	BLFC Fitting	1
A36	05056106	Brine Line Screen	1
A37	05056107	BLFC Tube Insert	1
A38	05056033	BLFC Ferrule	1
A39	05056108	BLFC Fitting Nut	1
A40	05056086	Screw-M5×30(Hexagon with Washer)	2
A41	05056029	Injector Cover	1
A42	05056072	O-Ring- φ 24×2	
A43	05056103	Injector Screen	1
A44	05056027	Injector Nozzle	1
A45	05056028	Injector Throat	1
A46	05056177	Injector Body	1
A47	05056075	Injector Seat	1
A48	05056134	O-Ring- φ 12×2	1
A49	05056054	Injector Stem	1
A50	05056031	Injector Spacer	1
A51	05056081	O-Ring- φ 12.5×1.8	1
A52	05056030	Injector Cap	1
A53	05056093	Injector Screen	1
A54	05010049	Special Washer	1
A55	05056105	Retaining Ring	1
A56	05056067	O-Ring- φ 7.8×1.9)	2
A57	05056037	Air Disperser	1
A58	05056066	O-Ring- φ 11×2	1
A59	05056055	BLFC Plug	1
A60	05056156	Injector Nozzle(Filter)	1
A61	05056117	Injector Plug	1

## Trouble Shooting

Issue	Possible Cause	Possible Solution
A. Unit fails to initiate a regeneration cycle.	1. No power supply.	Check electrical service, fuse, etc.
	2. Defective circuit board.	Replace faulty parts.
	3. Power failure.	Reset time of day.
B. Water is hard.	1. By-pass valve open.	Close by-pass valve.
	2. Out of salt.	Add salt to tank.
	3. Plugged injector / screen.	Clean parts.
	4. Flow of water blocked to brine tank.	Check brine tank refill rate.
	5. Hard water in hot water tank.	Repeat flushing of hot water tank required.
	6. Leak between valve and central tube.	Check if central tube is cracked or o-ring is damaged. Replace faulty parts.
	7. Internal valve leak.	Replace valve seals, spacer, and piston assembly.
C. Salt use is high.	1. Refill time is too high.	Check refill time setting.
D. Low water pressure.	1. Iron or scale build up in line feeding unit.	Clean pipes.
	2. Iron build up inside valve or tank.	Clean control and add resin cleaner to clean bed. Increase regeneration frequency.
	3. Inlet of control plugged due to foreign material.	Remove piston and clean control valve.
E. Resin in drain line.	1. Air in water system.	Check well system for proper air eliminator control.
	2. Incorrect drain line flow control (DLFC) button.	Check for proper flow rate.
F. Too much water in brine tank.	1. Plugged injector or screen.	Clean parts.
	2. Valve not regenerating.	Replace circuit board, motor, or control.
	3. Foreign material in brine valve.	Clean parts.
G. Unit fails to draw brine.	1. Drain line flow control is plugged.	Clean parts.
	2. Injector or screen is plugged.	Clean parts.
	3. Inlet pressure too low.	Increase pressure to 25 PSI.
	4. Internal valve leak.	Replace seals, spacers, and piston assembly.
H. Valve continuously cycles.	1. Defective position sensor PCB.	Replace faulty parts.
I. Flow to drain continuously.	1. Valve settings incorrect.	Check valve settings.
	2. Foreign material in control valve.	Clean control.
	3. Internal leak.	Replace seals, spacers, and piston assembly.

# NovoSoft Guarantee

**Novo Water Conditioning Products** guarantees that your new water conditioner is built of quality material and workmanship. When properly installed and maintained, it will give years of trouble free service.

## Five Year Complete Parts Guarantee

**Novo Water Conditioning Products** will replace any part which fails within 60 months from date of manufacture as indicated by the serial number, provided the failure is due to a defect in material or workmanship. The only exception shall be when proof of purchase or installation is provided and then the warranty period shall be from the date thereof.

## Ten Year Guarantee on Mineral Tanks and Brine Tanks

**Novo Water Conditioning Products** will provide a replacement mineral tank or brine tank to any original equipment purchaser in possession of a tank that fails within 120 months, provided that the water conditioner is at all times operated in accordance with specifications and not subject to freezing.

## General Provisions

**Novo Water Conditioning Products** assumes no responsibility for consequential damage, labour or expense incurred as a result of a defect or for failure to meet the terms of these guarantees because of circumstances beyond its control.

