

Pumps

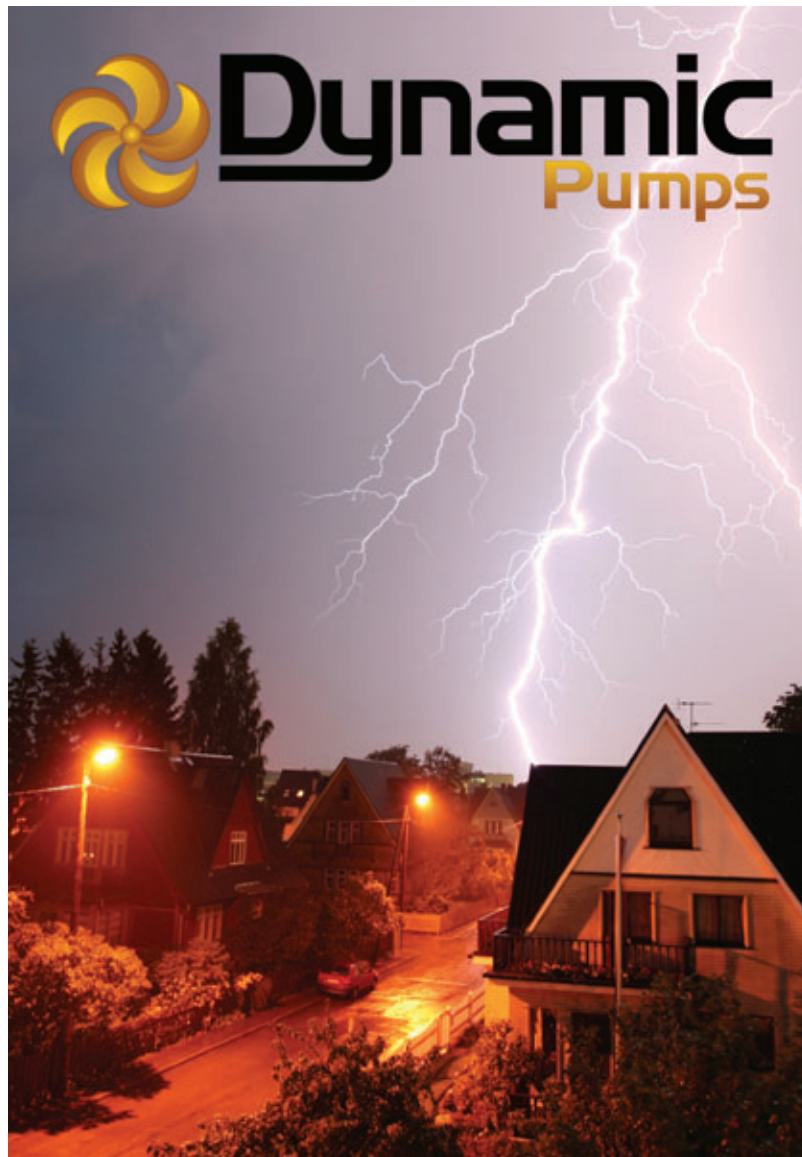

Submersible Sump
Column Sump
Sewage & Effluent

Submersible Sump Pumps

The Dynamic Professional Series Sump Pump offers you reliability and performance you can count on - all backed by a solid **Two Year Guarantee**. Use for basement sumps, moving ground water, draining pools, tank circulation and bailing applications.

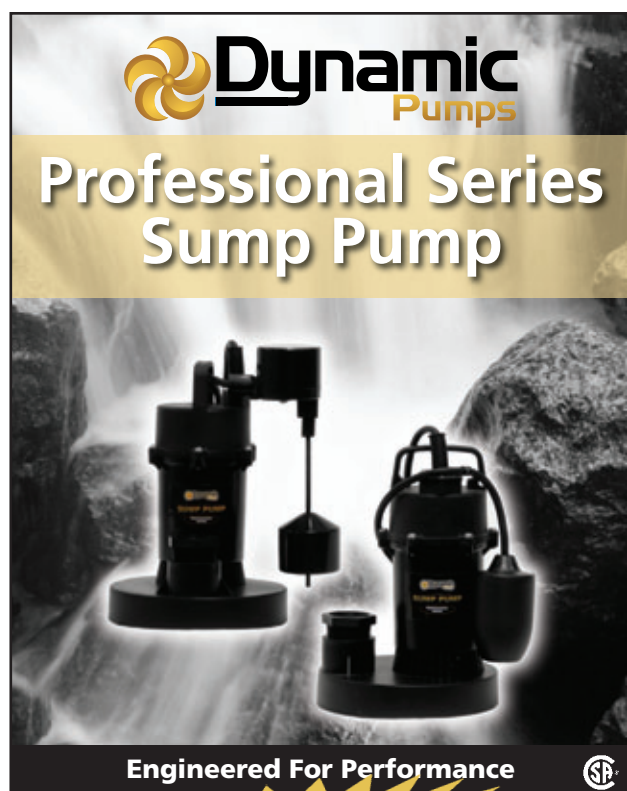

**2 Year
Guarantee**

Features:

- Available in 1/4, 1/3 & 1/2 hp
- 1 1/4" or 1 1/2" NPT Discharge Outlet
- Piggy-back vertical or tethered style float switch
- Screened top inlet prevents impeller and seal damage
- Aluminum die cast motor housing and engineered thermoplastic pump components for impact and corrosion resistance
- Efficient and reliable permanent split capacitor motor for high starting torque
- Permanently lubricated upper and lower heavy-duty motor bearings provide long motor life
- Built in thermal overload protection
- Thermoplastic vortex impeller provides superior low maintenance performance
- Carbon/Ceramic mechanical and lip seal for added motor protection
- 10 foot power cord /115 volt /60Hz
- Lift ring for easy installation and pump removal
- Stainless steel corrosion resistant exterior hardware

Laundry Sink Packages

For use with laundry sinks, wet bars, water softeners, dehumidifiers and capturing air conditioner condensation

Features:

- 1/4 & 1/3 hp Models available with vertical float switch
- Check valve included
- 1 1/2" NPT inlet, discharge, vent connections and power cord grommet included
- 6 U.S. Gallon Usable Capacity
- Modified octagonal shape maximizes capacity while minimizing space required.

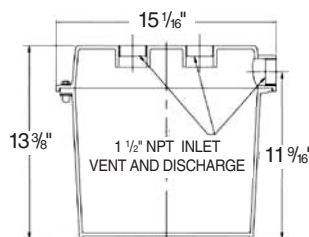

**Note: 1/3 hp model available pre-assembled
Refer to item #45010009 on page 76**

Submersible Sump Pumps

Performance Curves

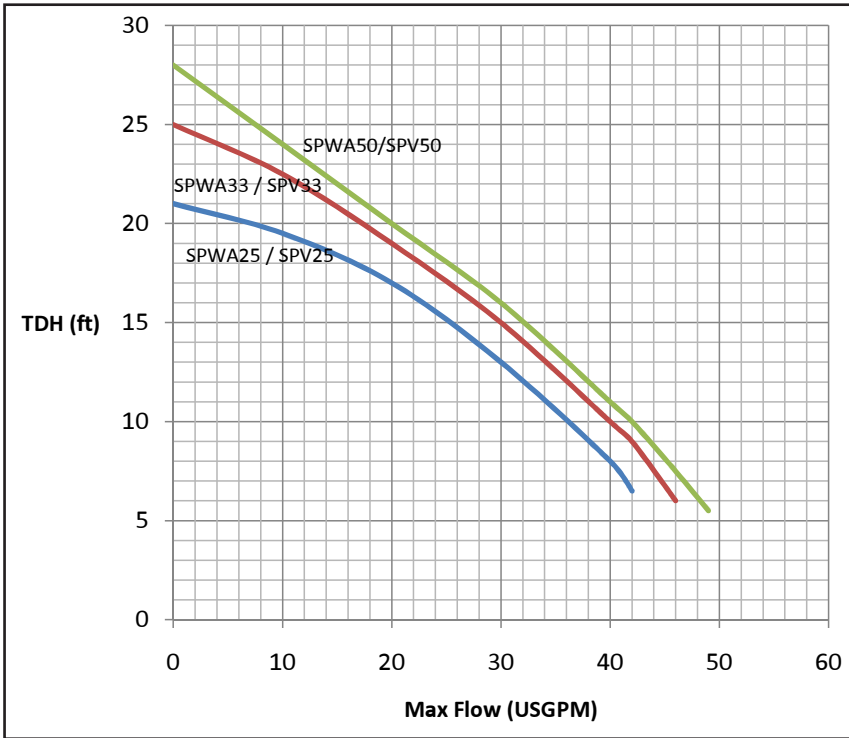

Dimensions

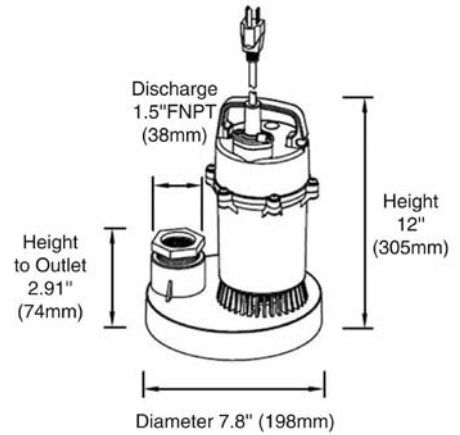

Submersible Sump Pump Specifications

Item #	Model Number	Description	TDH (ft/m)	* Max Flow (usgpm/lps)	Solids Handling	HP	Voltage	Frequency Hz	Rated Amp Draw	Output Power (W)	Motor Speed (rpm)	Weight (lb/kg)
45010001	SPWA25	Sump Pump - Tethered Switch	21/6.4	42/2.6	1/8"	1/4 HP	115	60	3.0	180	3500	8.4 / 3.8
45010002	SPWA33	Sump Pump - Tethered Switch	25/7.6	46/2.9	1/8"	1/3 HP	115	60	4.0	250	3500	8.8 / 4.0
45010003	SPWA50	Sump Pump - Tethered Switch	28/8.5	49/3.1	1/8"	1/2 HP	115	60	4.7	370	3500	9.9 / 4.5
45010004	SPV25	Sump Pump - Vertical Switch	21/6.4	42/2.6	1/8"	1/4 HP	115	60	3.0	180	3500	8.4 / 3.8
45010005	SPV33	Sump Pump - Vertical Switch	25/7.6	46/2.9	1/8"	1/3 HP	115	60	4.0	250	3500	8.8 / 4.0
45010006	SPV50	Sump Pump - Vertical Switch	28/8.5	49/3.1	1/8"	1/2 HP	115	60	4.7	370	3500	9.9 / 4.5

* Note: Maximum flow based on a minimum 6' Head

Laundry Sink Pump Package

Item #	Model Number	Description	TDH (ft/m)	* Max Flow (usgpm/lps)	Solids Handling	HP	Voltage	Frequency Hz	Rated Amp Draw	Output Power (W)	Motor Speed (rpm)	Weight (lb/kg)
45010008	SPV25 PKG	1/4 HP Pump Package	21/6.4	42/2.6	1/8"	1/4 HP	115	60	3.0	180	3500	20.4 / 9.3
45010009	SPV33 PKG	1/3 HP Pump Package - "Pre-Assembled"	25/7.6	46/2.9	1/8"	1/3 HP	115	60	4.0	250	3500	20.8 / 9.4

* Note: Maximum flow based on a minimum 6' Head

UnderSink Basin Only

Item #	Model Number	Description	Weight (lb/kg)
45070005	SF-06	13.5" x 15" Undersink Basin (6 Gallon)	8 / 3.6

Column Sump Pump

Dynamic Pumps provide the best value for an affordable sump pump line suitable for home, farm or cottage sump pump applications.



Features:

- Available in 1/3 hp
- 1 1/4" NPT Discharge Outlet
- Screened top suction inlet prevents debris from entering the pump and damaging the impeller
- Thermal overload motor protection
- Adjustable float switch for automatic operation
- Open-type impeller allowing small particles to pass without damage
- 8 foot power cord
- Thermoplastic and corrosion resistant pump body to ensure long life
- 2 Year Guarantee



Performance Curves

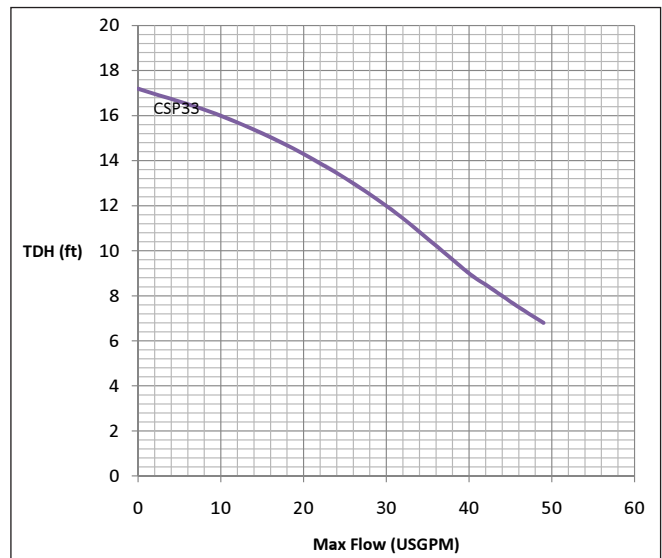

Dimensions

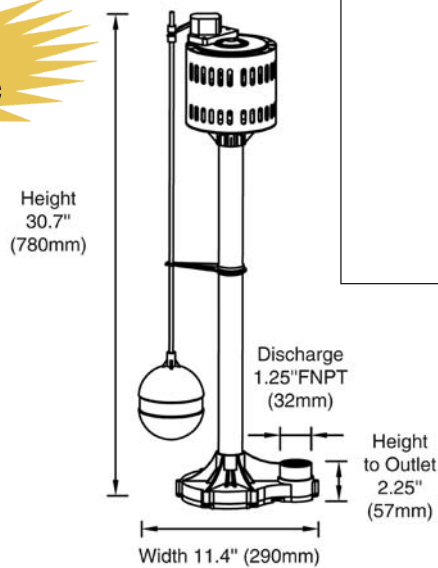

2 Year Guarantee

Column Sump Pump Specifications

Item #	Model Number	Description	TDH (ft/m)	* Max Flow (usgpm/lps)	Solids Handling	HP	Voltage	Frequency Hz	Rated Amp Draw	Output Power (W)	Motor Speed (rpm)	Weight (lb/ kg)
45010007	CSP33	Column Sump Pump	17/5.2	49/3.1	1/8"	1/3 HP	115	60	4.0	250	1750	12.8 / 5.8

*Note: Maximum flow based on a minimum 6.5' Head

Sewage & Effluent Pumps

The Dynamic Professional Series Sewage and Effluent pump provide reliability and performance you can count on – all backed by a solid two year guarantee. Designed for pumping septic tank effluent, heavy duty sump applications or 2" solids handling in domestic sewage applications for farm, home or cottage - Dynamic pumps give many years of trouble free service.

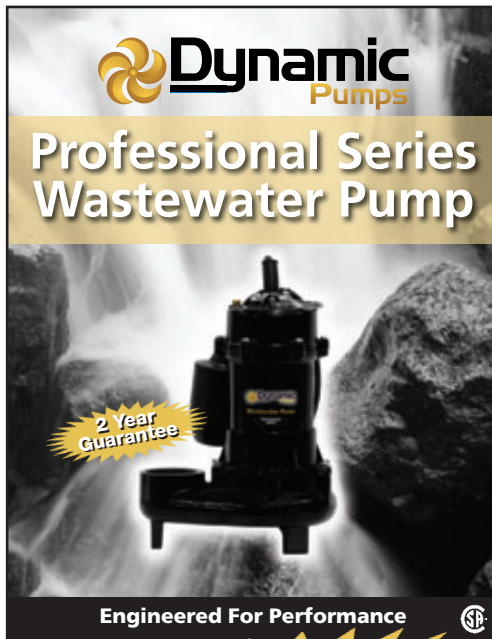

Features:

- Cast Iron Volute and Motor Housing ensure pump longevity
- Efficient and reliable ½ hp, 115 volt / 60 hz permanent split capacitor motor provides high starting torque
- Oil-filled motor housing provides permanent lubrication of the upper and lower heavy-duty motor bearings for longer motor life
- Built in Thermal Overload protection
- Thermoplastic vortex impeller provides low maintenance performance and superior solids handling capabilities
- Double lip seals for added motor protection
- 20 foot power cord makes for easy “plug in” installation to any standard 115 volt power outlet
- 20 foot “Piggy-back” style float switch makes for easy trouble shooting
- Stainless Steel Lift ring offers easy installation and pump removal
- Exterior hardware and lift ring made from stainless steel for added corrosion resistance
- 2 Year Guarantee
- Maximum operating temperature 50°C

2 Year Guarantee

Pre-Assembled Sewage Ejector Package:

- ½ hp – 2" solids handling sewage pump
- 24" x 24" (42 Gal.) polyethylene tank with cover provide superior design and reliability as well as ease of installation.
- 4" inlet, 2" discharge connection, 2" vent connection
- Power cord grommet included

Note: Other Pre-Assembled Sewage Ejector Packages also available on request.



Refer to item #45020006 on page 81



45070003
18.5" diameter x 30" high
(35 Gal)



45070001
24" diameter x 24" high
(42 Gal)



45070004
22" diameter x 33" high
(53 Gal)

*Tank may not be exactly as shown.

Sewage and Effluent Pumps

Performance Curves

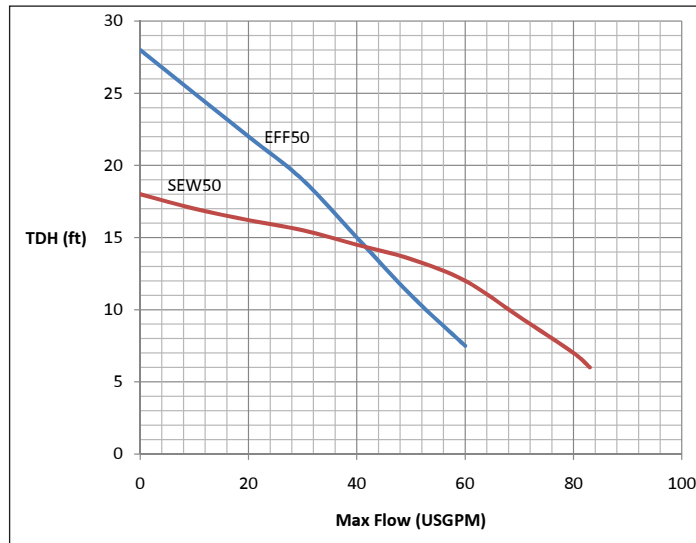

Dimensions

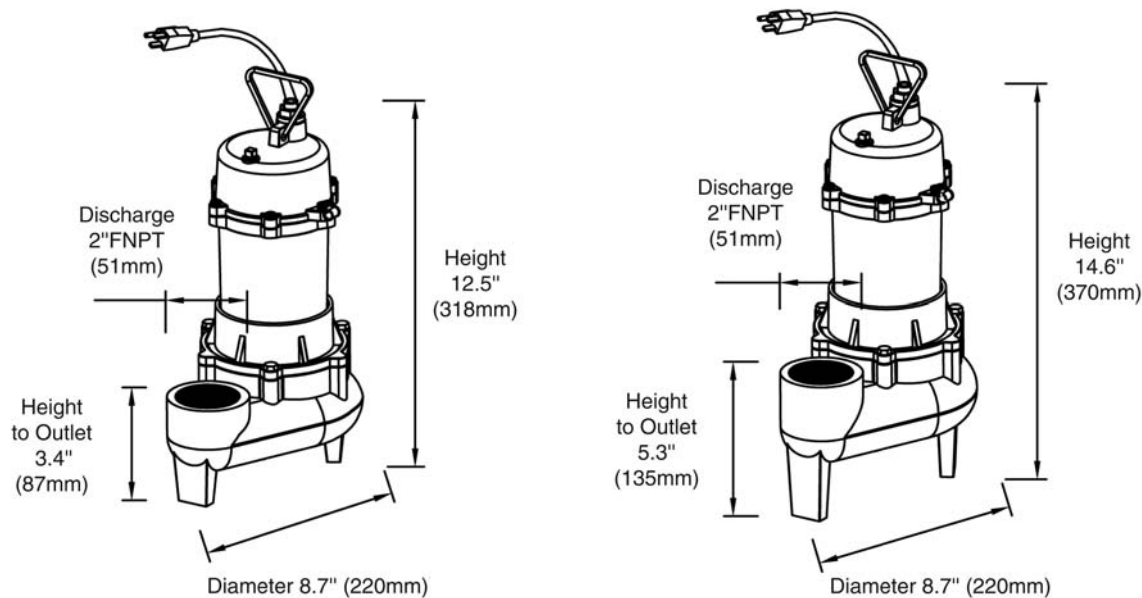

Sewage and Effluent Pump Specifications

Item #	Model Number	Description	TDH (ft/ m)	* Max Flow (usgpm/lps)	Solids Handling	HP	Voltage	Frequency Hz	Rated Amp	Output Power (W)	Motor Speed	Weight (lb/ kg)
45020001	EFF50	Effluent Pump	28/8.5	62/3.9	3/4"	1/2 HP	115	60	5.0	370	3500	19.8 / 9.0
45020002	SEW50	Sewage Pump	17/5.2	83/5.2	2"	1/2 HP	115	60	6.0	370	3500	22.0 / 10

* Note: Maximum flow based on a minimum 6' Head

Sewage Ejector Packages (Pump and Basin Shipped as separate items)

45020003		1/2 HP Sewage Package c/w 18.5" x 30" (35 US gal) basin	17/5.2	83/5.2	2"	1/2 HP	115	60	6.0	370	3500	42.8 / 19.4
45020004		1/2 HP Sewage Package c/w 24" x 24" (42 US gal) basin	17/5.2	83/5.2	2"	1/2 HP	115	60	6.0	370	3500	46.8 / 21.2
45020005		1/2 HP Sewage Package c/w 22" x 33" (53 US gal) basin	17/5.2	83/5.2	2"	1/2 HP	115	60	6.0	370	3500	48.8 / 22.1

Sewage Basin Only

45070003		18.5" x 30" (35 US gal) sewage basin										18 / 8.16
45070001		24" x 24" (42 US gal) sewage basin										22 / 9.98
45070004		22" x 33" (53 US gal) sewage basin										24 / 10.89

Item #	Model Number	Description	TDH (ft/ m)	* Max Flow (usgpm/lps)	Solids Handling	HP	Voltage	Frequency Hz	Rated Amp	Output Power (W)	Motor Speed	Weight (lb/ kg)
45020006		*Pre-Assembled* 1/2 HP Sewage Package c/w 24" x 24" (42 US gal) basin	17/5.2	83/5.2	2"	1/2 HP	115	60	6.0	370	3500	46.8 / 21.2

Marketing Tools

Showroom Posters



#80151024
Wholesale Showroom



#80151025
Plumbing Showroom

Softener Sizing Guide Sales Tool



#80151021



Water Sample Kit Counter Display

#80151022



#80151023

Banners (2' x 4')

Colour Literature

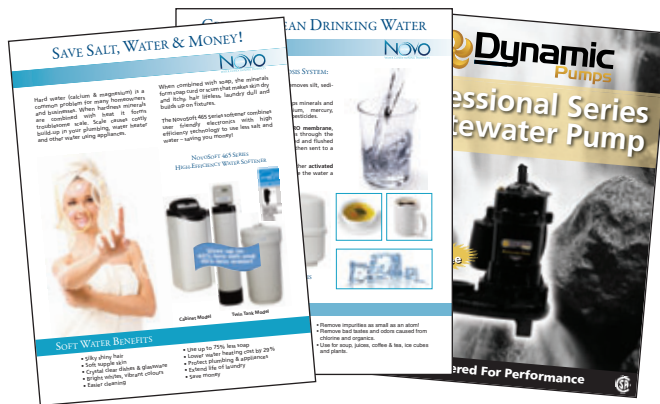

Literature

80151000	NOVO Product Catalogue
80151001	NOVO 2010 Price List
80151002	NOVO 165 Water Softener
80151003	NOVO 465 Water Softener
80151004	NOVO 465 Whole House Filter
80151005	NOVO Reverse Osmosis
80151006	NOVO Specialty Systems (SIM/ST)
80151007	NOVO C850 Mini Softener (Mailer Sized)
80151008	NOVO C850 Mini Softener
80151009	NOVO Undersink Filtration System
80151010	NOVO UltraViolet Sterilizers
80151011	NOVO Tomlinson Faucets
80151012	NOVO POU Cooler
80151013	NOVO UV Filter System
80151014	NOVO Amtrol RO Storage Tank
80151016	NOVO HTO Two Tank Softener / Carbon
80151017	NOVO BIF Chem Free Iron Filter
80151018	NOVO Distiller
80151019	NOVO Commercial
80151020	NOVO CDA Brochure
80152000	Dynamic Sump Pump
80152001	Dynamic Sewage & Wastewater Pump

www.novowater.com

You will find a wealth of helpful information when you visit www.novowater.com. Download manuals, literature and newsletters. Learn about new product introduction and awesome promotions geared to seeing your business grow!



NEWS

- May 16th - [NSF Certification of Control Valves](#)
- Apr. 20th - [Steve Jackson Announcement](#)
- Feb. 7th - [Novo Announces First Canadian Product Showcase Event Dates](#)

SAVE TIME, SPACE & MONEY
Reduce time and space with the NOVOsoft

New Posters
New 485 Water Softener Showroom Posters Now Available
[> More Information](#)



World Class Manufacturing
Our 700,000 square foot ISO9000:2000 plant Redefines state-of-the-art.
[> Learn why our quality is superior](#)

[Home](#) [About Us](#) [Specials](#) [Quality](#) [Products](#) [Contact Us](#)

© Canature NA 2010
655 Park St.
Regina, SK S4N 5N1 Canada





Pump Products For The Plumbing Professional

