



Ultraviolet Disinfection System

Models: AQUV-8R1



- 1. This manual contains important safety and operating instructions. Read all instructions and follow them when using this product. Failure to consider this information and follow these instructions, including those concerning maintenance, may result in property damage, injury and or death.**
- 2. We recommend installation only be completed by a competent installer or plumbing professional to insure this product is installed in accordance with local plumbing codes.**
- 3. Test the water periodically to verify that the system is performing satisfactorily.**
- 4. Discard small parts remaining after the installation.**
- 5. Failure to install the system correctly voids the warranty.**
- 6. Handle all components of the system with care. Do not drop, drag or turn components upside down.**
- 7. Save these instructions and keep track of your product's serial number.**

NOTICE: THIS MANUAL CONTAINS A LIMITED WARRANTY. BY INSTALLING AND OR USING THIS PRODUCT, YOU WAIVE CERTAIN LEGAL RIGHTS INCLUDING THE RIGHT TO SUE OR CLAIM COMPENSATION IN THE EVENT OF PROPERTY DAMAGE, INJURY, AND OR DEATH.

BRAND: AQUA FLO.
MODELS: AQUV-8R1

Canature WaterGroup Canada Inc.
855 Park St.
Regina, SK, S4N 6M1
CANADA
Toll Free: (877) 288-9888

Canature WaterGroup U.S.A. Inc.
6353 Commerce Drive
Whitestown, IN, 46075
USA
Toll Free: (877) 288-9888

Page intentionally blank

Congratulations on purchasing this ultraviolet disinfection system. By purchasing an AQUA FLO UV Disinfection system you are receiving not only a high quality product but also peace of mind. Protecting your water supply with a UV system gives you reassurance that your family will have access to safe drinking water throughout your entire home. This is a chemical free process which is simple in its concept and effective in its abilities to inactivate microorganisms present in the water supply. Simple maintenance, continuous disinfection and ultimately safe water, AQUA FLO makes it that easy.

A. INTRODUCTION	4
B. SAFETY GUIDELINES	4
C. WATER QUALITY REQUIREMENTS	6
D. INSTALLATION	6
E. DISINFECTION PROCEDURE	10
F. BALLAST FOR AQUV UV SYSTEMS	10
G. OPERATION AND MAINTENANCE	11
H. TROUBLESHOOTING	12
I. TECHNICAL SPECIFICATIONS	13
J. PARTS LIST	13
K. WARRANTY	16

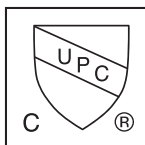

Certified by IAPMO R&T against NSF/ANSI/CAN 61, 372 and CSA B483.1 for material safety, structural integrity and lead free requirement.

Additional testing and verification for UV dose performed by independent laboratory.

(A) INTRODUCTION

Your AQUV-8R1 features a two-stage design. The first stage is a 5 micron sediment filter that reduces dirt, rust, sand and other fine particulate matter. Stage two is a UV system that instantly destroys pathogenic bacteria (such as coliform, E. coli, viruses, etc) in the water using germicidal ultraviolet light emitted by a specially engineered UV lamp at 254 nm wavelength. Treated water flows out of the chamber and is ready for use (See Fig 1).

UV systems are used around the world as a primary disinfectant as it is a natural, non-chemical, environmentally safe technique that is not known to form any harmful disinfection by-products.

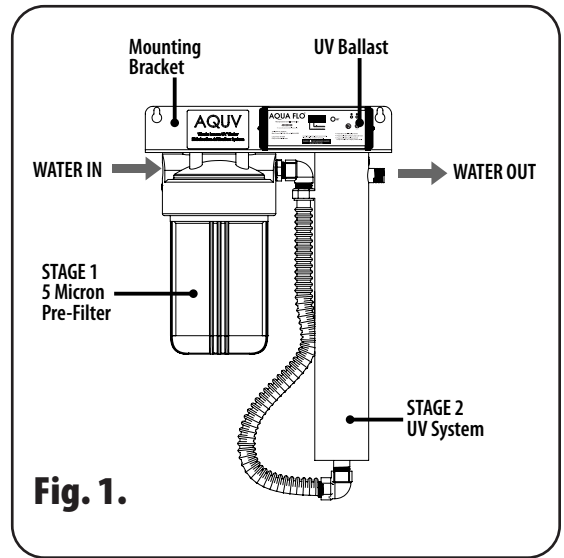

(B) SAFETY GUIDELINES



This is the safety alert symbol. When you see this symbol, look for one of the following signal words:



Indicates a hazardous situation which, if not avoided, will result in death or serious injury and/or property loss or damage.



Indicates a hazardous situation which, if not avoided, could result in death or serious injury and/or property loss or damage.



Indicates a hazardous situation which, if not avoided, could result in minor or moderate injury and/or property loss or damage.



Indicates important information, that if not followed, may result in damage to the equipment.



Contains mercury

- Lamp contains mercury (Hg).
- Dispose or recycle in accordance with applicable laws.
- For information on safe handling procedures and safe disposal and recycling, consult :

Diverting Mercury



Management of Lamps Containing Mercury:



(B) SAFETY GUIDELINES (CONTINUED)

- **To avoid** possible electric shock, extra care should be taken since water may be present near electrical equipment. Unless specifically referred to in these instructions, do not attempt repairs yourself. Do not plug the unit in if any electrical surfaces or electrical parts are wet.
- **DO NOT LOOK DIRECTLY AT UV LAMP WHEN LAMP IS ON.** UV light can cause serious burns to eyes and skin.
- **Do not** operate the UV lamp outside the UV disinfection chamber.
- **Do not** use this unit for any purpose other than its intended use for potable water disinfection. The use of attachments not recommended, approved or sold by the manufacturer may result in improper performance of the unit or an unsafe condition and void the product warranty.
- **Do not** operate the system if it has a damaged electrical cord or plug, is malfunctioning, or has been damaged in any way.
- **Do not** touch the lamp or quartz dome with dirty or moist hands. Hold the lamp and dome by the ends with soft dry gloves or cloth.
- Before any cleaning or maintenance on the system, always unplug the unit from the power source.
- Disconnect power cable from the power outlet by holding the plug. Never pull the cord.
- To comply with the National Electrical Code and to provide additional protection from the risk of electric shock, this system should only be connected to a properly grounded, grounding-type controller receptacle that is protected by a Ground Fault Circuit Interrupter (GFCI).
- Ensure that the lamp connector ground wire is connected to the grounding stud on the chamber.
- Installation of the UV disinfection system and water filter will interrupt electrical grounding continuity of your plumbing system. For directions on restoring the electrical grounding continuity, consult a certified electrician
- Protect your unit from freezing and weather elements.



WARNING

To ensure continuous protection, **UV LAMP MUST BE REPLACED ANNUALLY**. After 1 year of use, it will no longer provide effective disinfection even though it stays lit.



WARNING

USE ONLY **GENUINE AQUA FLO AQUV LAMPS**. Use of non-Aqua Flo AQUV UV lamps can result in unsafe drinking water, which may lead to illness and/or death, ballast failure or fire, and will void your product warranty. (see page 12 for details)

Canature WaterGroup U.S.A. Inc. / Canature WaterGroup Canada Inc. (Canature) has disclosed all known risks associated with the product within this manual but cannot disclose risks that are beyond its knowledge.

(C) WATER QUALITY REQUIREMENTS

The unit should only be operated with water that meets the following minimum criteria:

- **Turbidity/Suspended Solids:** Ideally less than 1 NTU (Nephelometric Turbidity Unit). If the feed water has fine sediment, a finer pre-filter (1 micron or smaller) may be used. If the water has very high turbidity, a back-washable multi-media filter is recommended along with a cartridge type filter.
- **Hardness:** Less than 7 GPG (120 mg/L). Hard water causes scale build-up on the quartz sleeves thereby reducing the UV transmittance in the water and in turn reduced performance. The UV system will work with hard water for a short time after which the scale build-up on the quartz dome will cause reduced disinfection performance (unsafe condition). It is therefore recommended that, for hard water, a water softener should be installed prior to the UV system.
- **Iron & Manganese:** Iron less than 0.3 PPM (mg/L) and Manganese less than 0.05 mg/L is desirable. At higher concentrations, a suitable water conditioner (e.g. an Iron Filter or Greensand filter) should be installed prior to the UV system to prevent iron build-up on the quartz dome that can cause insufficient disinfection.
- **Tannins and Colour:** Water with tannins or colour has low UV transmissivity that reduces UV system performance. The UV system will not work if the water has tannins or colour. A tannin-removal system should be installed for proper disinfection.

(D) INSTALLATION

INSTALLATION NOTES AND CAUTIONS:

- The Aqua Flo AQUV Water Disinfection System is designed for installation on the cold water line only at the point of entry (POE). The system must be installed in accordance with all local, state or provincial regulations.
- The system requires a constant power supply of 110V AC.
- It is strongly recommended to have a dedicated electrical circuit for the UV system. A CSA or equivalent certified surge protector must be installed to protect the ballast from electrical surges. We recommend surge protector rated for a clamping voltage of less than 400 Volts, response time of less than one nanosecond, and energy absorption of at least 600 Joules.
- The AQUV-8R1 system has been designed for maximum water flow rates of 8 US GPM (30 liters per minute). If higher flow rates exist occasionally, it is recommended that a flow restricter be installed at the inlet port(8 US GPM for AQUV-8).
- The system should be installed indoors in a protected area where the temperature does not fall below 4°C (40°F).
- For optimum performance, the system should be wall-mounted in a vertical position with the lamp connector at the top.
- It is highly recommended to install bypass piping with a shut-off valve around the unit. This way you can still have water in case you need to remove the UV unit for service.
- Provide a minimum clearance of 2 feet above the unit for lamp replacement.
- Use only Teflon tape for all connections. Do not use any other sealant on the threads.

DIMENSIONS

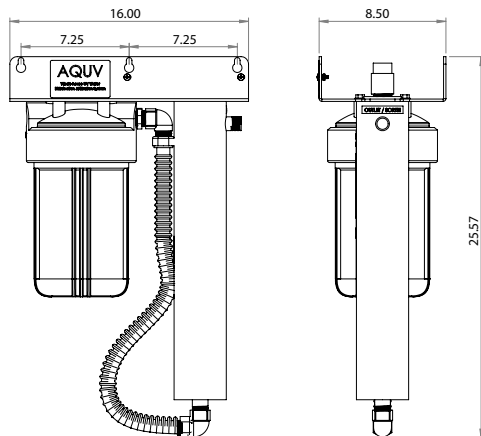

CAUTION!

** Install a pressure regulator and water hammer arrestor if pressure exceeds maximum rating of 100 psi at any time. Note: If daytime pressure is over 80 psi, night time pressure may exceed maximum pressure rating.

NOTICE

Check with your local public works department for applicable local plumbing and sanitation codes. Follow local codes if they differ from the standards used in this manual. Otherwise, carefully follow the instructions in this manual. Canature is not liable for any non-compliance with local requirements

Unpacking the UV System

Your UV system includes the following items:

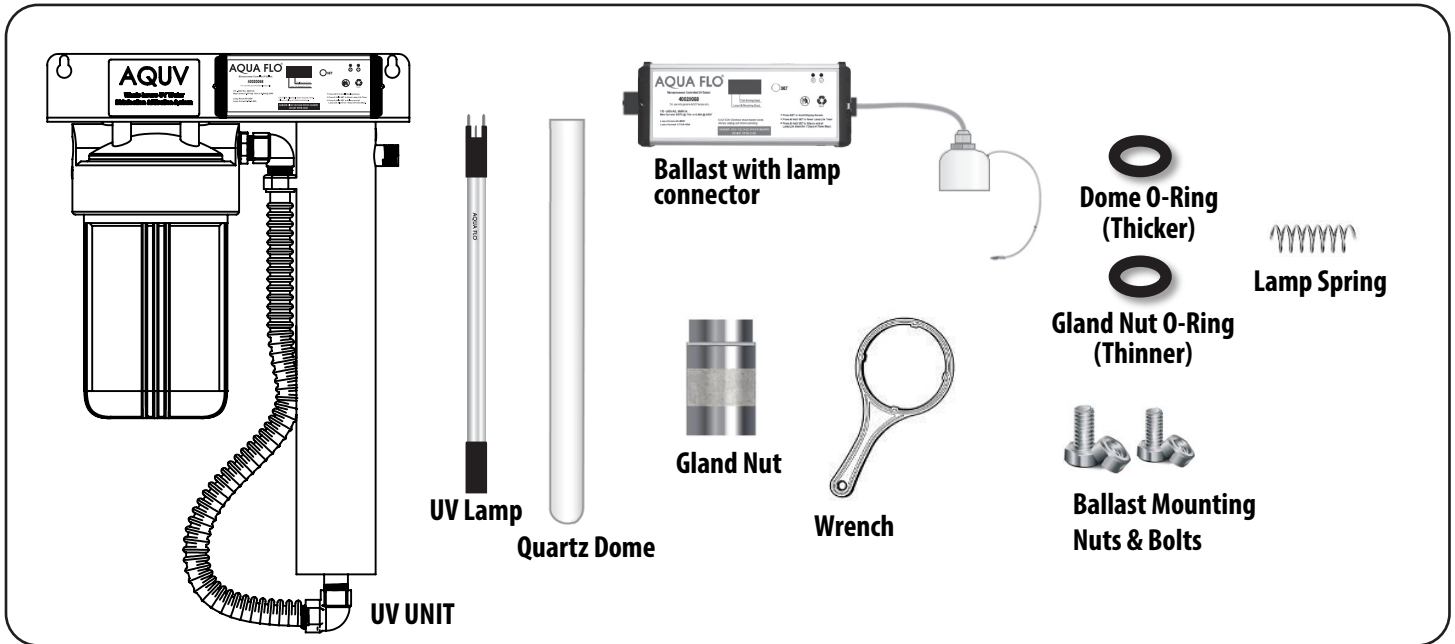

Install Location

If your water comes from a well or a lake/river etc., the UV should be installed after your pump and pressure tank. To prevent damage to the UV system, do not install it between well pump and pressure tank. If you have other water filters/conditioner installed, such as softener/iron filter etc., the UV system should always be installed as the last step of treatment before the water pipes divide into hot and cold (Fig 2).

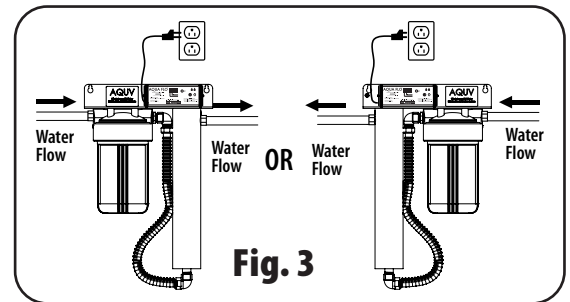
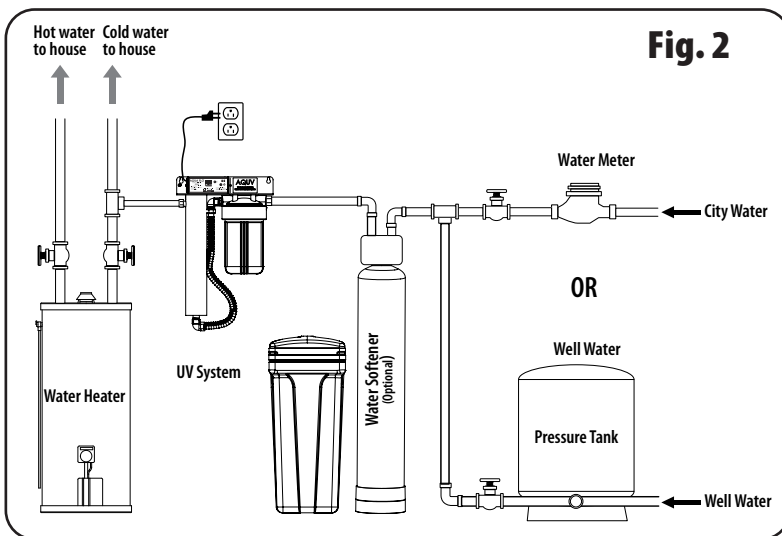

Fittings Required for Installation (Not Included)

Fittings required for a typical install on 3/4" copper pipe are 3/4" FNPT female adapters, 3/4" Tee, 3/4" Elbows, 3/4" copper pipe, 3/4" union couplings and 3/4" ball valves. You may need different fittings if your pipe size or material is different. If you are unsure of what fittings to use, please call Aqua Flo.



UV light can degrade plastics over time. If your water pipe is plastic (such as PEX), it is recommended that you use at least 6 to 12 inches of UV-resistant material (e.g. copper) on the inlet and outlet of the UV unit to prevent damage, and potential flooding.

Installing the AQUV Rack System

1. There are two mounting holes on the mounting bracket. Both of them should be mounted directly on to a wall stud with appropriate screws to carry the weight of the unit. Included mounting hardware only works for studs, they are lag bolts and a hole will need to be drilled to put them in without cracking the stud.

WARNING!

Do not mount the unit directly on drywall without appropriate reinforcement

2. Install new plumbing using (Fig 2) as reference of how the final installation should look.
3. Unscrew the filter sump and remove the sanitary wrap from the filter cartridges. Reinsert the new cartridge into the sump and screw the sump back onto the filter. Hand-tighten only.

CAUTION!

DO NOT USE WRENCH TO TIGHTEN SUMP.

4. Carefully unpack UV lamp and quartz dome. Two o-rings come with the quartz dome. The thinner o-ring is installed in the groove of the gland nut.

NOTE

Hold lamp and dome by the ends with soft, dry gloves or cloth. lamp needs to stay perfectly clean, any dirt or fingerprints on the lamp will reduce the life.

5. Gently slide the dome O-ring (thicker) over the top (open end) of the quartz dome to about 1" from the open end (Fig 4).
6. Gently insert the quartz dome into the gland nut and gently rotate the dome while pushing in until it goes past the nut O-ring and touches the inside top end of the gland nut. (Fig 5).
7. Carefully slide the quartz dome with gland nut attached into the opening at the top of the UV chamber (Fig 6A & 6B) and hand-tighten the gland nut into place.

CAUTION!

Do not over-tighten the gland nut as it can break the quartz dome.

NOTE

Broken quartz domes are not covered under warranty.

8. Slowly open supply-valve and valves before and after UV system. **Check for leaks. Do not proceed to next step until leaks are fixed.**

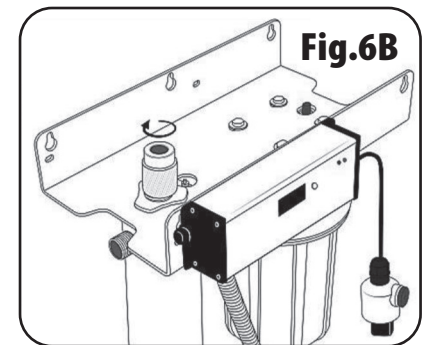
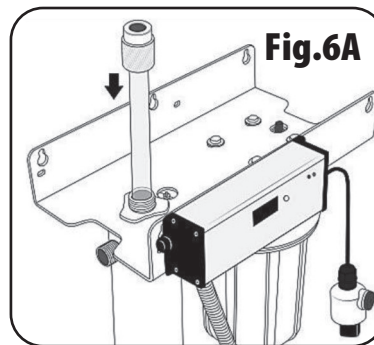
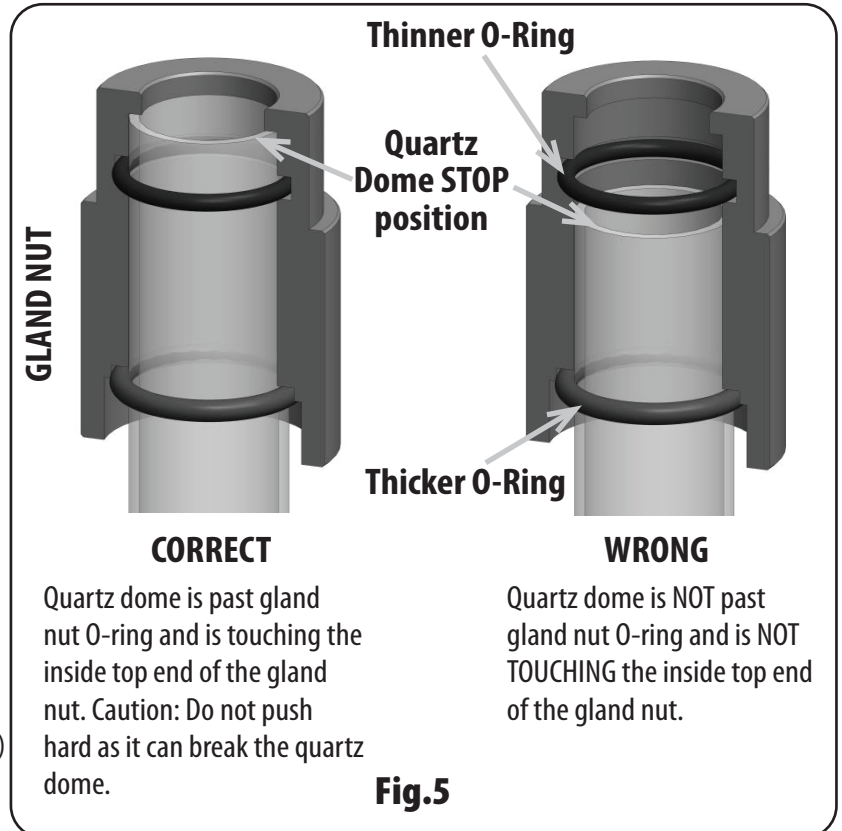
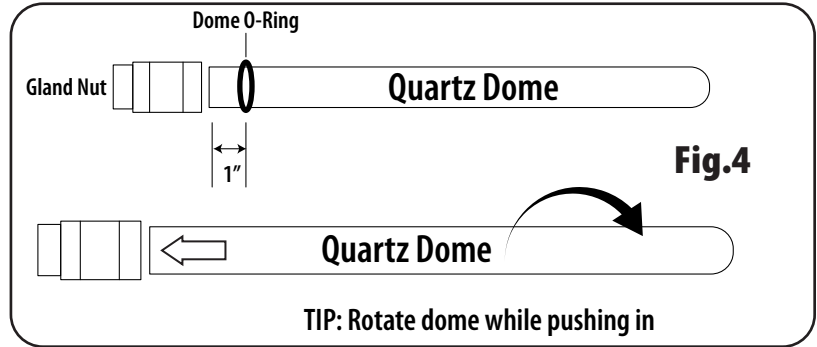

NOTE

Do not use pipe dope or tape on these top threads before attaching gland nut.

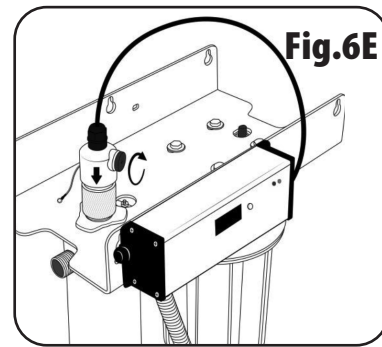
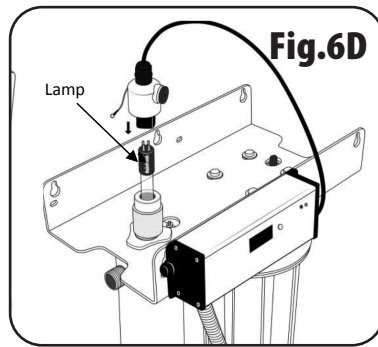
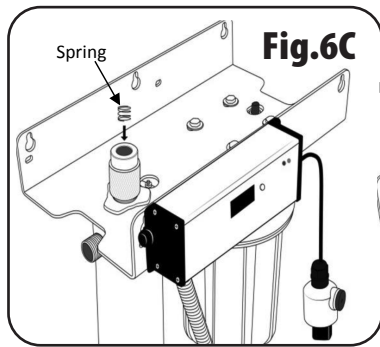

8. From the top of the gland nut, drop the lamp spring into the quartz dome **Fig. 6C**.
9. Holding the top 4-pin end of the lamp, carefully slide the lamp into the quartz dome and attach the lamp pins to the lamp connector. The lamp connector fits over the pins in only one orientation **Fig. 6D**.
10. Slide the lamp connector cover over the gland nut and tighten the screw on it **Fig. 6E**. Check tightening details, the screw allows the cord to come through the plastic making it easy to hook up lamp, then white plastic part has a little screw to secure it to the gland nut.
11. Remove the nut from the ground stud at the top of the unit. Next place the ground wire (green wire with yellow stripes) over the stud and tighten the nut.
12. Connect the ballast power cable to the AC supply (with surge protector). The green lamp-on LED will light up and the display will show "365". This number indicates the number of days left until lamp life expires and must be replaced. Follow Step (E) before consuming water.

! WARNING

Installing lamp without the spring in place can cause breakage of quartz dome.

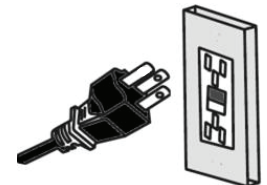
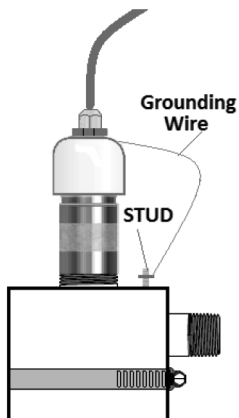

YOUR AQUA FLO AQUV UV DISINFECTION SYSTEM IS NOW READY FOR SERVICE.

(E) DISINFECTION PROCEDURE

Before service begins, all household plumbing lines should be disinfected to prevent the possibility of re-contamination after UV disinfection. You should also disinfect your plumbing system if the power goes out for several hours or more or if the unit has been accidentally shut-off for several hours or more. It is advisable to disinfect the plumbing lines at least once a year. Disinfect after using bypass as well.

The following is a general method for disinfection of plumbing lines. If you are uncertain about the efficacy of this procedure you are advised to contact your local health authority responsible for water safety.

1. Shut off the supply valve and de-pressurize the lines by opening a tap until it runs dry.
2. Remove the filter in the filter housing and add about 1-2 cups (250-500ml) of unscented household bleach (5 to 6% sodium hypochlorite) to the empty filter housing and put it back on the filter head.
3. Open the supply valve and slowly open a faucet and let the water run until you can smell the chlorine and then shut the faucet off. Repeat the procedure for all hot and cold outlets in the house. Add more bleach as required. Run hot faucets longer to allow the chlorine to come through the hot water tank.
4. Leave the bleach solution in the plumbing system for about 6 to 8 hours preferably overnight.
5. Shut-off the supply valve again and open a faucet to depressurize the system. Open the filter housing and re-install the filter cartridge and then re-attach the filter housing. Make sure that the UV system is ON.
6. Take off aerators (if any) on the faucets, open the supply valve slowly, and thoroughly flush all outlets until the chlorine smell is minimal.
7. You are ready to use the water now.



WARNING

Failure to follow disinfection procedure could result in micro-biologically unsafe water leading to potential illness or death.

(F) BALLAST FOR AQUV UV SYSTEMS

Aqua Flo AQUV advanced micro-processor controlled electronic UV ballast is for use with Aqua Flo AQUV-8, AQUV12 & AQUV-20 Systems. It features both audio and visual alarm indicators to indicate the lamp operation and an integral annual lamp change reminder timer.

0365 **NORMAL DISPLAY:** Number of days left before lamp expires and must be replaced. Starts at 365 and ends at 0.

0000 Press button to display the total running days of the unit since installation (maximum 9999 days). Display goes back to default after 10 seconds.

LF **"LF" - LAMP FAULT:** If the lamp is disconnected or defective (burned out), the display will show "LF" with the red LED on, and the ballast will beep every 2 seconds. If you press the button once, display will show "lamp life remaining" and go back to "LF" after 10 seconds. If you press the button again before 10 seconds, display will show "total running time" and then after 10 seconds go back to "LF". In the "LF" alarm do not consume water until you replace UV lamp and cleared the alarm.

A3 **"A3" - LAMP EXPIRY:** If the display shows "A3" alarm with red LED on and ballast beeps every 5 seconds, it indicates that the lamp has expired. Do not consume water until lamp is replaced.

dELY You can silence the alarm for 7 days by pressing and holding the button until "dELY" is displayed. You can silence the alarm 3 times after which the alarm will not silence until you replace the UV lamp.

rSET **RESETTING THE LAMP EXPIRY TIMER:** After replacing the UV lamp annually, you must re-set the ballast timer to clear the "A3" alarm. To do this press and hold the button for approx 10 seconds until "rSET" is displayed. Release button and the ballast will emit a long beep to confirm reset. Green LED will come on and red LED will turn OFF. Display will show "365" again.

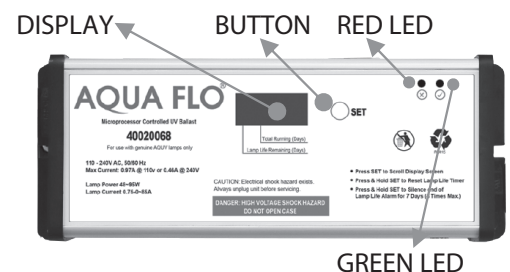

(G) OPERATION AND MAINTENANCE

Your UV system is ON continuously during normal use and will continuously supply safe water. (Note: Do not try to shut it off during short periods of non-use as repeated ON/OFF cycles can shorten the UV lamp and ballast life). Failure to follow disinfection procedure if the system is shut off could result in micro-biologically unsafe water leading to potential illness or death.

To maintain the optimum disinfection performance of the UV system:

- UV lamp should be replaced when the display reaches "0". At this point, the UV lamp continues to light but its ability to disinfect the water drops below safe limits. Therefore the **UV lamp MUST BE REPLACED WHEN THE LAMP REPLACEMENT ALARM "A3" COMES ON.**
- The quartz dome should be cleaned at the time of lamp replacement. If the water quality parameters listed in section 'C' are exceeded, you should clean and inspect the quartz dome more frequently and clean as necessary.
- Replace pre-filters every 4-6 months.

ITEM	REPLACEMENT FREQUENCY	CLEANING
UV Lamp	Every 1 year of use	N/A
Quartz Dome	Every 3 years	At least during every annual lamp change. More frequently if water is hard or has iron, manganese etc.
O-Rings	Annually	N/A
Sediment Pre-Filter	6 months or when pressure across the unit drops by 10psi	N/A



WARNING

USE ONLY GENUINE AQUA FLO AQUV LAMPS

Use only GENUINE AQUA FLO AQUV UV Lamps with your UV system. Aqua Flo UV lamps are designed with extensive product research and engineering to provide reliable and consistent UV output and performance that ensures the safety of your drinking water. Using non-Aqua Flo AQUV UV lamps can not only compromise the system performance but also voids your product warranty, electrical and CSA certification, and may result in any one or more of the following issues:

- Unsafe drinking water which may lead to illness and/or death
- Ballast failure
- Electrical fire

Use of non-Aqua Flo AQUV lamps will void all warranty & product certification

Genuine Aqua Flo AQUV lamps can be identified as follows:



CHANGING FILTER CARTRIDGES & REPLACING O-RINGS:

1. Shut off the inlet valve and open a faucet close by until pressure in the unit is relieved. Alternatively you can press the red vent button on top of the unit until pressure is released.
2. Place an empty bucket under the sump to catch any water spilling out of the housings.
3. Using the supplied wrench, unscrew the sump. Discard old cartridge and rinse sump.
4. Remove O-rings and replace if they have been in use for a year. Otherwise wipe them with a soft cloth or paper towel and clean the groove on which the O-rings are seated.
5. Apply food-grade silicone lube on the O-rings and replace.
6. Clean inside of the head as well to make sure the sealing surface is free of debris and stains.
7. Insert new cartridge into the sump and screw sump back on to filter. Hand-tighten only. Slowly open the water and flush for a few minutes before use.

CAUTION!

DO NOT USE WRENCH TO TIGHTEN SUMP.

How to replace the UV Lamp and clean Quartz Dome:

1. Unplug UV unit from electrical outlet and turn off supply valve before the unit. Open a faucet to depressurize the UV system and turn off the valve at the UV outlet to isolate UV unit. **CAUTION:** The lamp end can be very hot. Wait several minutes for the lamp to cool down.
2. Unscrew the ground nut and remove the ground wire (green wire with yellow stripes).
3. Loosen the screw on the lamp connector cover and remove cover from the gland nut.
4. Carefully slide UV lamp slightly out of chamber and hold the lamp end with one hand. Gently pull off the connector with your other hand to disconnect the lamp completely. Slowly remove lamp from the disinfection chamber completely.
5. Remove the quartz dome by loosening the gland nut and carefully extracting from the unit. Remove dome absolutely vertically from its position until the other end comes out. **CAUTION:** If you bend the dome mid-way, it can break easily and pieces of quartz can fall into the UV chamber. Do not lose the spring.
6. Clean dome gently with a vinegar solution or a household scale-removal product. **Do not use abrasive pads.** A soft cloth or paper towel is recommended.
7. If replacing quartz dome, carefully take the gland-nut O-ring out of the gland nut. Take care not to scratch the gland nut.
8. A dome O-ring (thicker) and gland nut O-ring (thinner) are included with the replacement lamp. Slide gland nut O-ring into the internal groove of the gland nut.
9. Follow instructions 7 to 15 in previous section "Installing the UV Unit". Do not plug in ballast yet.
10. **Depress timer button while reconnecting ballast** to electrical outlet and keep the button depressed until the ballast emits a solid three-second beep. This will re-set the lamp-change-timer to zero and the 3-second beep will confirm that the re-set was successful.

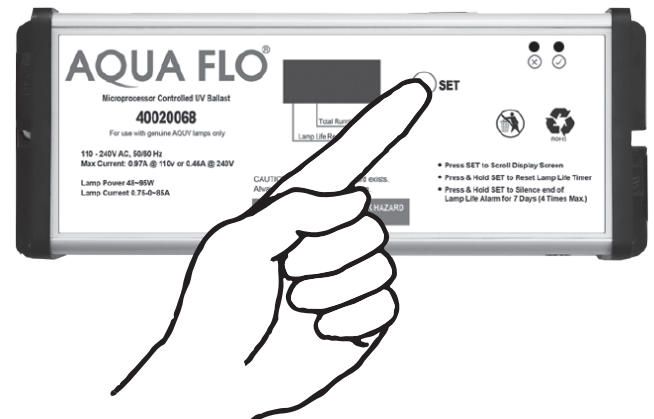

Winterizing Your System:

To winterize the system, unplug the unit first. Drain the pre-filter by removing the sump and dump the water, then drain the UV chamber of all water. Let the filter cartridge dry out and then reinstall in the housing. To drain the UV, undo the SS flex connector from the bottom until the UV drains completely. Re-attach the flex connector. Leave the UV lamp and dome inside. When turning unit back on, plug the ballast first and slowly allow water into the unit. Wait for about 10 minutes and flush water through for a few minutes before consuming water.

(H) TROUBLESHOOTING

PROBLEM	PROBABLE CAUSE	SOLUTION
Leak at gland nut	Gland nut is loose or O-ring defective	Hand-tighten gland nut & replace O-ring(s)
Condensation outside the UV chamber	High humidity in the environment	This is normal if humid conditions exist. Install dehumidifier to protect ballast. Protect floO-ring below UV
Hot water coming out of taps/faucets	Water inside UV unit becomes hot after long periods of non-use. You may have oversized the unit for the home	To prevent scalding, before using water after periods of non-use such as overnight, flush water for about 2 minutes. Install a temperature controlled purge valve on the UV outlet
UV lamp ends seem burnt after some time	This is normal	As long as the UV lamp lights, a little burn mark at the ends is normal and there is no need to replace the UV lamp
Sump is difficult to remove	<ul style="list-style-type: none"> •Unit may still be under pressure •Head seal may be stuck to sump 	<ul style="list-style-type: none"> •Close supply valve and open a faucet to release pressure •To break the seal, use a pipe on the wrench handle as extra leverage to open the housing. Never use wrench to tighten the sumps. Always lubricate the O-rings with food grade silicone and replace annually
Leak at pressure relief valve	Debris under vent seal	Replace vent O-ring

(I) TECHNICAL SPECIFICATIONS

Category	AQUV-8R1
Maximum flow rate @ 30 mJ/cm ² *	8 gpm / 30 lpm
Maximum flow rate @ 40 mJ/cm ² *	5 gpm / 19 lpm
Lamp service life	9000 Hours
Lamp Power	35 watt
Power Consumption	35 watt
Annual lamp change timer	Yes
Lamp-ON Indicator	Yes
Audio/Visual alarms	Yes
Chamber material	304 Stainless Steel
Chamber dimensions (D x L)	3.5" x 16.0"
Controller dimensions (L x W x D)	8" x 3" x 2.25"
Inlet/Outlet port size	3/4"NPT
AC supply voltage	120V, 50/60Hz, 0.8A
Maximum operating pressure	100psi
Water temperature range	2 - 40°C (36-104°F)
Shipping Weight	26.5lb / 12kg

*Dosage based on a UVT value of 96%

(J) PARTS LIST

Item as Labelled	PART NUMBER	DESCRIPTION	QTY
1	40020068	Ballast, power cord & lamp connector assembly	1
2	80126734	Ballast mounting bolts	2
3	80126718	Ballast mounting nut	2
4	430335	SS UV Chamber for AQUV-8	1
5		Gland Nut	1
6	89587	Chamber Mounting SS Nut	1
7	36003037	Quartz Dome for AQUV-8	1
8	80127302	Dome O-Ring (Thicker)	1
9	80127301	Gland Nut O-Ring (Thinner) – inside nut	1
10	89112	UV Lamp for AQUV-8	1
11	80127402	Lamp Spring	1
12	36053	Pre-filter head	1
		Sump for pre-filter	1
		Pressure vent button	1
		BH Mounting screw	4
		BH mounting washer	4
		Wrench to open pre-filter housing	1
13	36281	5 micron sediment cartridge	1
14	60010559	Sump O-rings	2
15	80036768	1"x3/4" reducer bushing	1
16	80036304	SS 3/4" Street elbow	1
17	80030391	3/4" Close Nipple	1
18	80127829	3/4" x 3/4" Flex Tube, 24"	1
19	89588	UV Bracket - Single Sump	1
20	80036770	3/4" Street elbow	1

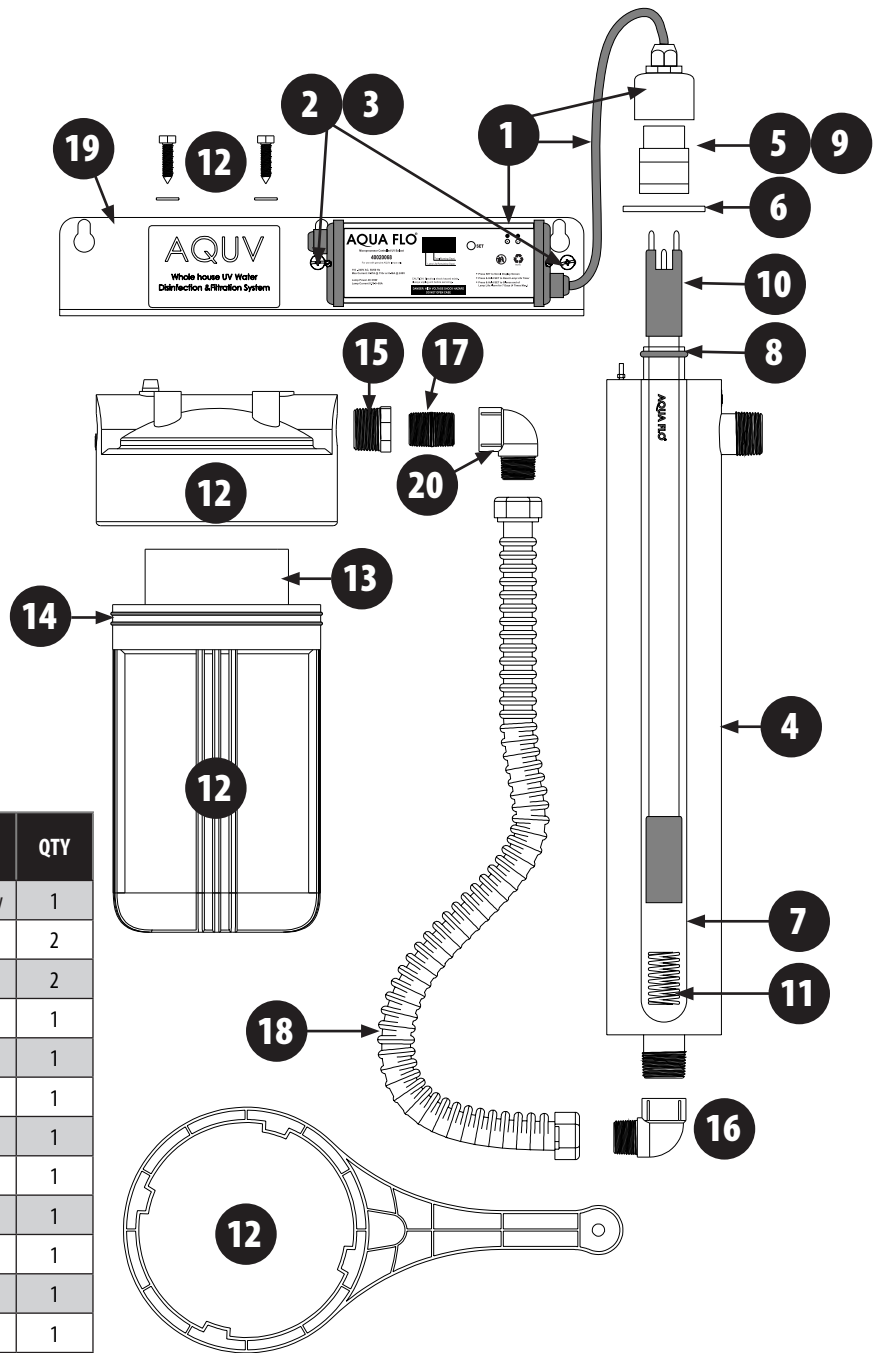

Replacement Parts

System	AQUV-8R1
Item #	40030104
Lamp	89112
Quartz Dome	36003037
Controller	40020068
5 Micron Sediment Cartridge 10"	36281

Page intentionally blank

Page intentionally blank

(K) LIMITED WARRANTY

The Ultraviolet Water Disinfection Systems stainless steel housing is warranted to the original purchaser for a period of seven (7) years, from the date of purchase, against defects in materials and workmanship. The Ultraviolet Water Disinfection Systems miscellaneous hardware, seals and electrical system are warranted to the original purchaser for a period of one (1) year, from the date of purchase, against defects in materials and workmanship. The Ultraviolet lamp and quartz sleeve are warranted for a period of thirty (30) days from the date of purchase against defects in materials and workmanship.

Subject to the conditions and limitations described below, this product, if returned to us with proof of purchase within the stated warranty period and if covered under this warranty, will be repaired or replaced (with the same model, or one of equal value or specification) – at our option. We will bear only the cost of any repair or replacement.

The purchaser is responsible for communication of all necessary information regarding the application and use of product.

Under no circumstances will Canature be responsible for any other direct or consequential damages, including but not limited to travel expenses, rented equipment, outside contractor fees, unauthorized repair shop expenses, lost profits, lost income, labour charges, delays in production, idle production, which damages are caused by any defect in material and/or workmanship and/or damage or delays in shipment.

This warranty is expressly in lieu of any other express or implied warranty, including any warranty of merchantability or fitness for a particular purpose and excludes all other express or implied warranties to the extent permitted by law.

For clarity, where exclusion is not permitted by law, those express or implied warranties are not excluded by this warranty.

This warranty is subject to the following conditions and limitations:

1. This warranty will not apply if water passing through the Ultraviolet Disinfection System has:
 - a) Turbidity / Suspended Solids: More than 1.0 NTU.
 - b) Hydrogen Sulphide concentrations greater than 0.05 PPM (0.05 mg/l).
 - c) Iron concentration greater than 0.3 ppm (0.3 mg/l) or Manganese greater than 0.05 ppm (0.05 mg/l).
 - d) Hardness concentrations greater than 7 GPG (119 PPM).
 - e) Tannins or colour.
2. A bill of sale verifying the purchase and purchase date must be provided.
3. This warranty will NOT apply to any product or part thereof which is worn or broken or which has become inoperative due to abuse, misuse, accidental damage, neglect, or lack of proper installation, operation or maintenance (as outlined in the applicable owner's manual or operating instructions) or which is being used for industrial, professional, commercial, or rental purposes
4. This warranty will not apply to normal wear and tear or to expendable parts or accessories that may be supplied with the product which are expected to become inoperative or unusable after a reasonable period of use.
5. This warranty will NOT apply to any product that was sold to the original purchaser as a reconditioned or refurbished product unless otherwise specified in writing.
6. This warranty will NOT apply to any product or part thereof if any part from another manufacturer is installed therein or any repairs or alterations have been made by unauthorized person(s).
7. This warranty will NOT apply to normal deterioration of the exterior finish, such as, but not limited to scratches, dents, paint chips, or to any corrosion or discoloring by heat, abrasive, and chemical cleaners.



Canature WaterGroup Canada Inc.

855 Park St.
Regina, SK, S4N 6M1
CANADA
Toll Free: (877) 288-9888

Canature WaterGroup U.S.A. Inc.

6353 Commerce Drive
Whitestown, IN, 46075
USA
Toll Free: (877) 288-98888