

Dimensions

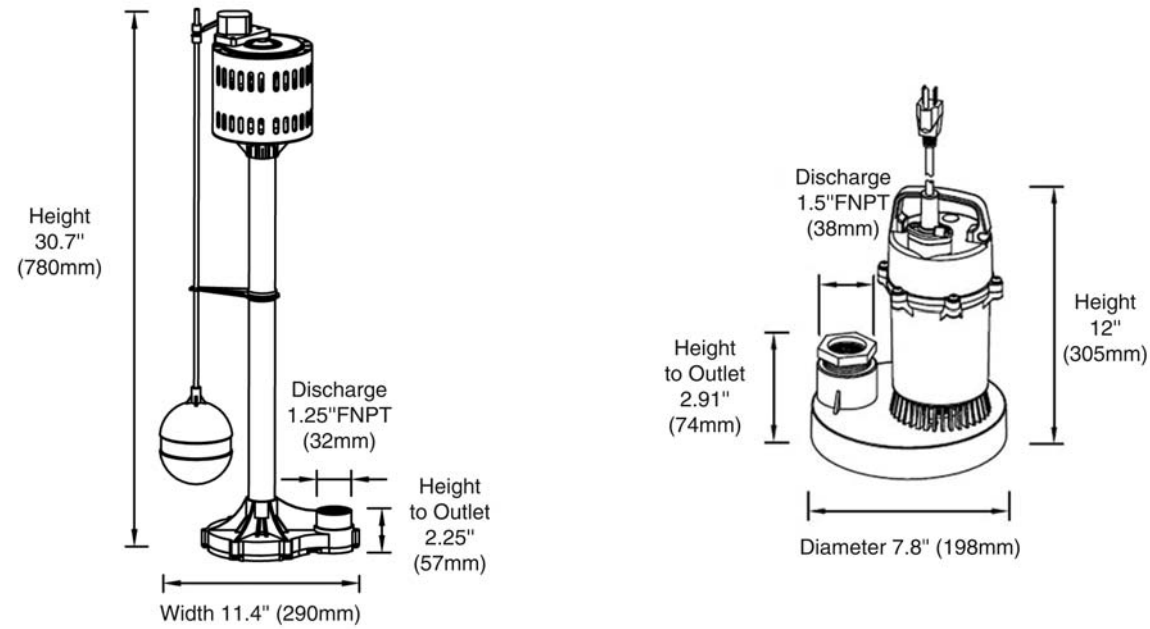

Specifications



Submersible Sump Pump Specifications

Item #	Model Number	Description	TDH (ft/m)	* Max Flow (usgpm/lps)	Solids Handling	HP	Voltage	Frequency Hz	Rated Amp Draw	Output Power (W)	Motor Speed (rpm)	Weight (lb/kg)
45010001	SPWA25	Sump Pump - Tethered Switch	21/6.4	42/2.6	1/8"	1/4 HP	115	60	3.0	180	3500	8.4 / 3.8
45010002	SPWA33	Sump Pump - Tethered Switch	25/7.6	46/2.9	1/8"	1/3 HP	115	60	4.0	250	3500	8.8 / 4.0
45010003	SPWA50	Sump Pump - Tethered Switch	28/8.5	49/3.1	1/8"	1/2 HP	115	60	4.7	370	3500	9.9 / 4.5
45010004	SPV25	Sump Pump - Vertical Switch	21/6.4	42/2.6	1/8"	1/4 HP	115	60	3.0	180	3500	8.4 / 3.8
45010005	SPV33	Sump Pump - Vertical Switch	25/7.6	46/2.9	1/8"	1/3 HP	115	60	4.0	250	3500	8.8 / 4.0
45010006	SPV50	Sump Pump - Vertical Switch	28/8.5	49/3.1	1/8"	1/2 HP	115	60	4.7	370	3500	9.9 / 4.5

* Note: Maximum flow based on a minimum 6' Head

Column Sump Pump Specifications

Item #	Model Number	Description	TDH (ft/m)	* Max Flow (usgpm/lps)	Solids Handling	HP	Voltage	Frequency Hz	Rated Amp Draw	Output Power (W)	Motor Speed (rpm)	Weight (lb/kg)
45010007	CSP33	Column Sump Pump	17/5.2	49/3.1	1/8"	1/3 HP	115	60	4.0	250	1750	12.8 / 5.8

* Note: Maximum flow based on a minimum 6.5' Head

Laundry Sink Pump Package

Item #	Model Number	Description	TDH (ft/m)	* Max Flow (usgpm/lps)	Solids Handling	HP	Voltage	Frequency Hz	Rated Amp Draw	Output Power (W)	Motor Speed (rpm)	Weight (lb/kg)
45010008	SPV25 PKG	1/4 HP Pump Package	21/6.4	42/2.6	1/8"	1/4 HP	115	60	3.0	180	3500	20.4 / 9.3
45010009	SPV33 PKG	1/3 HP Pump Package - "Pre-Assembled"	25/7.6	46/2.9	1/8"	1/3 HP	115	60	4.0	250	3500	20.8 / 9.4

* Note: Maximum flow based on a minimum 6' Head

UnderSink Basin Only

Item #	Model Number	Description	Weight (lb/kg)
45070005	SF-06	13.5" x 15" Undersink Basin (6 Gallon)	8 / 3.6



Canature USA Inc. (Golden Valley, MN);
Canature North America Inc.
(Regina, SK; Kitchener, ON)

Your Dynamic Pump Dealer:

80152000 09/10



Professional Series Sump Pump



Engineered For Performance

Engineered For Performance



The Dynamic Professional Series Sump Pump offers you reliability and performance you can count on - all backed by a solid **two year guarantee**. Use for basement sumps, moving ground water, draining pools, tank circulation and bailing applications.



Submersible Sump Pumps

- Available in 1/4, 1/3 & 1/2 hp
- 1 1/4" or 1 1/2" NPT Discharge Outlet
- Piggy-back vertical or tethered style float switch
- Screened top inlet prevents impeller and seal damage
- Aluminum die cast motor housing and engineered thermoplastic pump components for impact and corrosion resistance
- Efficient and reliable permanent split capacitor motor for high starting torque
- Permanently lubricated upper and lower heavy duty motor bearings provide long motor life
- Built in thermal overload protection
- Thermoplastic vortex impeller provides superior low maintenance performance
- Carbon/Ceramic mechanical and lip seal for added motor protection
- 10 foot power cord /115 volt /60Hz
- Lift ring for easy installation and pump removal
- Stainless steel corrosion resistant exterior hardware
- 2 year guarantee

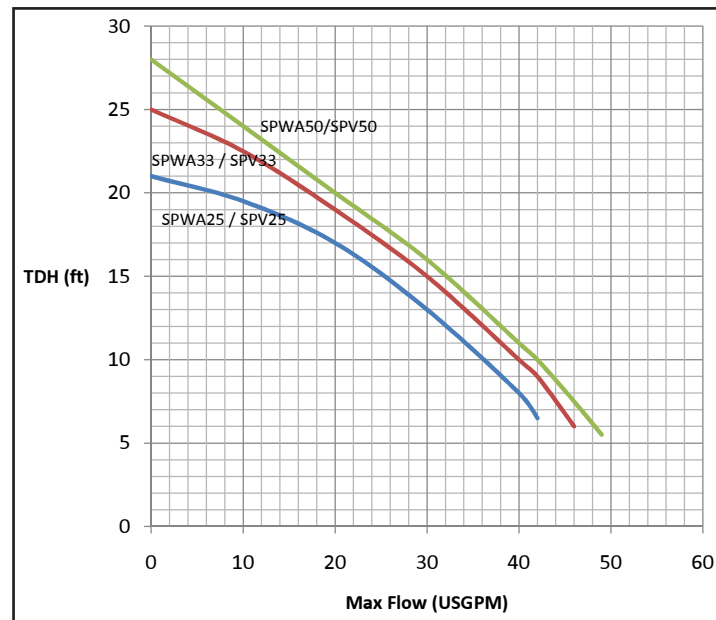

Column Sump Pump

- Available in 1/3 hp
- 1 1/4" NPT Discharge Outlet
- Screened top suction inlet prevents debris from entering the pump and damaging the impeller
- Thermal overload motor protection
- Adjustable float switch for automatic operation
- Open-type impeller allowing small particles to pass without damage
- 8 foot power cord
- Thermoplastic and corrosion resistant pump body to ensure long life
- 2 year guarantee

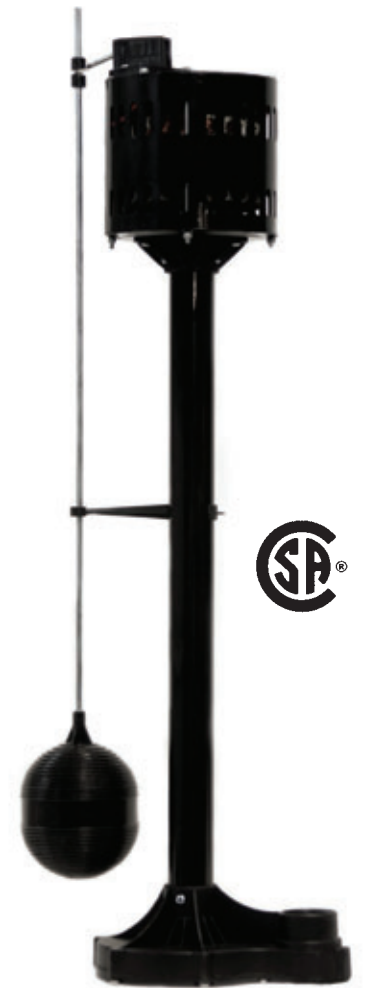
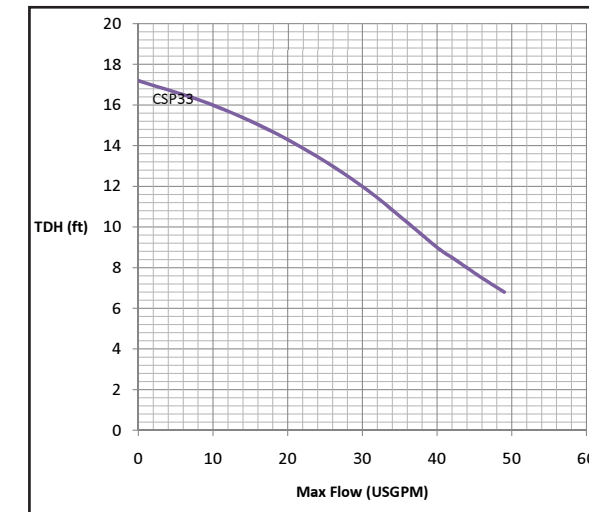

Laundry Sink Packages

For use with laundry sinks, wet bars, water softeners, dehumidifiers and capturing air conditioner condensation.

Features:

- 1/4 & 1/3 hp Models available with vertical float switch
- Check valve included
- 1 1/2" NPT inlet, discharge, vent connections and power cord grommet included
- 6 U.S. Gallon Usable Capacity
- Modified octagonal shape maximizes capacity while minimizing space required.

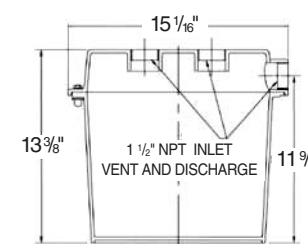

Note: 1/3 hp model available pre-assembled